

SC720 SERIES*

Analog Torque/Velocity or Digital Position Command Controllers
3.8A to 60A continuous current
7.5A to 120A peak

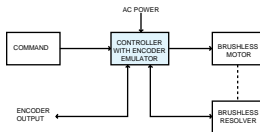

SC720 Controllers
are UL Recognized
(File E137798)

- Economical analog control with integral power supply
- Removable analog or digital personality module for easy setup and maintenance
- Digital personality module accepts step and direction or quadrature encoder position commands for connection to an indexer or for electronic gearing
- Single and multi-axis use
- Total front access to clearly marked connections
- Quadrature encoder output signals derived from single resolver feedback
- Inaudible, high frequency PWM current control
- 5 power levels
- 7 segment controller status display
- UL recognition

Designed specifically for use in harsh industrial environments, SC720 Series controllers provide economical velocity or torque control. Five power levels, SC722 through SC726, are ideal for use with Pacific Scientific's full torque range of brushless servo motors, R20 through R80 Series.

When used in combination with Pacific Scientific motors, SC720 Series controllers provide continuous torque ranging from 4.8 lb-in. to 451 lb-in. and peak torque from 10 lb-in. to 800 lb-in.

Thanks to modular design, wiring, setup and operating procedures are identical for all models in the SC720 Series. Standard motor power and feedback cables are available to assure reliable, troublefree system startup and operation.

INPUT POWER FEATURES

Each SC720 model is a stand-alone, 4-quadrant controller equipped with an internal power supply and shunt regulator. Separate AC inputs are provided for control logic and bus power.

The control logic can be powered while power is removed from the motor, placing the motor in a safe state while preventing loss of encoder or fault information. Control logic power can be 90-264 Vac single phase. Bus power can be 120 Vac single phase or 240 Vac single or three phase on the SC722 and SC723 and is 240 Vac three phase on the SC724, SC725 and SC726.

SINGLE RESOLVER FEEDBACK

The SC720 Series uses a single frameless resolver mounted on the motor shaft for rugged, reliable feedback. The resolver provides all necessary feedback information for commutation, velocity and position control.

Position feedback information from the resolver is processed by the drive electronics to produce signals which emulate an incremental encoder. These quadrature encoder output signals are available for use by an external position controller, including PLC servo modules.

The outputs are differential line drivers and have selectable resolution of up to 1024 pulses per revolution (4096 PPR optional).

Pacific Scientific offers resolver equipped, brushless rare earth and ferrite magnet servo motors ideal for use with the SC720.

PERSONALITY MODULE

The personality module contains all motor and application-specific drive settings and parameters. Easily removed and installed, these modules simplify setup, installation and maintenance while reducing spare part requirements.

All adjustments on the Analog Personality Module are potentiometers, jumpers or switches. All adjustments on the Digital Personality Module are set by a computer over a serial communications port and stored in EEPROM.

The Analog Personality Module allows for analog command of motor shaft torque or velocity. The Digital Personality Module allows for these same modes plus digital position commands in step and direction or quadrature format. These commands may be used for electronic gearing or come from

Peak torque range:
10.0 to 800 lb-in.
(1.1 to 90 Nm)



an indexer for position profiling or multi-axis control. The Digital Personality Module also features automated setup of adjustments and the ability to change adjustment settings via the serial port while the controller is operating.

The SERCOS Personality Module allows access to the Pacific Scientific multi-axis controller via the SERCOS standard fiber optic communication interface.

ADVANCED POWER CIRCUITRY

Insulated gate bipolar transistor (IGBT) technology in the SC720's output stage achieves high bandwidth 20 kHz PWM control. IGBTs simultaneously reduce circuit complexity, cost and package size.

A proprietary custom integrated circuit performs the processing for motor commutation and drive protection. This custom IC further reduces cost and size, while increasing reliability.

OPERATING FEATURES

- Smooth, high bandwidth velocity/torque control
- Transformerless, direct 240/120 Vac single or three phase line operation
- IGBT PWM output stage
- Phoenix screw terminal connections
- Fully enclosed, panel mount package
- Integral, directional dynamic braking

ADJUSTMENTS

- All adjustments are on the personality module
- Analog Personality Module option uses potentiometers, jumpers and a DIP switch—Digital Personality Module option stores all adjustment settings in EEPROM
- Loop adjustments:
 - Velocity loop gain
 - Anti-resonance filter
 - Command gain
 - Offset
 - Current limit
 - Position loop gain (digital option only)
 - Position command gain (digital option only)
- Selection settings:
 - Velocity/torque/position control select
 - Tachometer gradient (4 settings)
 - Emulated encoder PPR (4 settings)
 - 4 or 8 pole motor selection

PROTECTION/DIAGNOSTICS

- 7 segment status/fault code display
- Front access test points
- Inrush current limiting
- Fully fused
- MOV protected input
- Output short circuit protection
- Overtemperature protection, controller and motor
- I * T protection
- 3 bit fault code output

DIMENSIONS $\frac{\text{in.}}{\text{mm}}$ (metric dimensions for ref. only)*

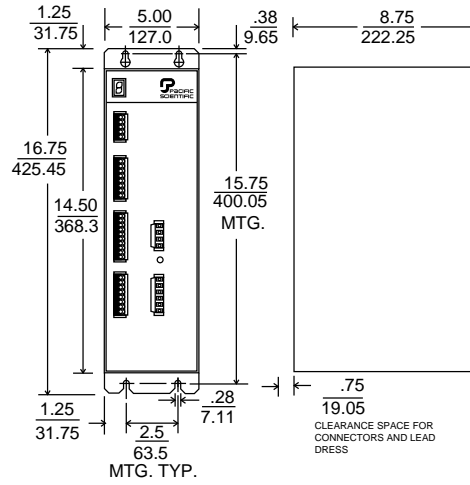

SC722/SC723

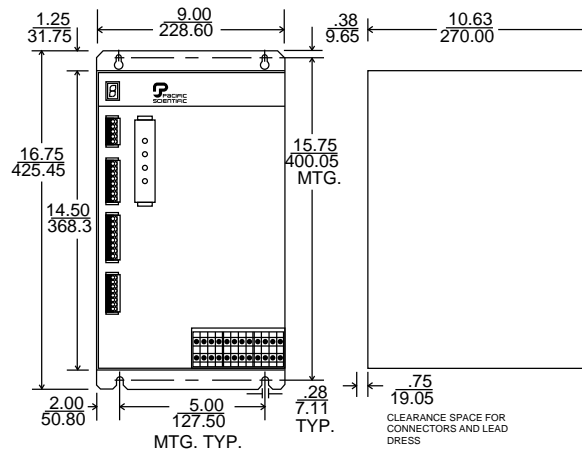

SC724/SC725

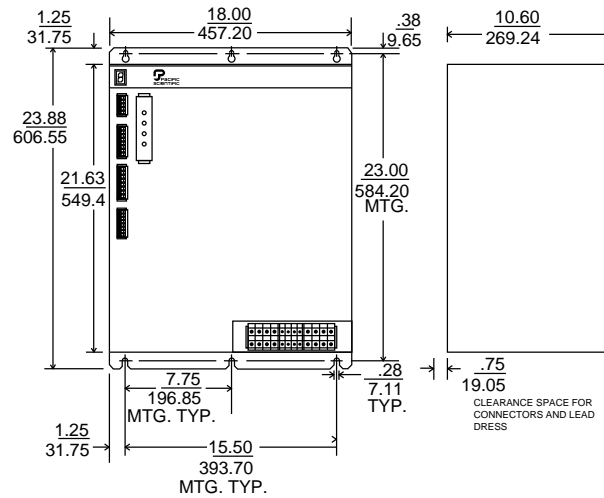

SC726

*See pages B-6 through B-26 for information on the next generation Servo Position Control.

GENERAL . . . SC720 Series Controllers*

Efficiency (50% output voltage, rated cont. current)	> 95%
Form factor	< 1.01
Current loop bandwidth	.750 to 3000 Hz
Velocity offset	.Adjustable to zero
Velocity offset drift (referred to input)	.50 μ V/ $^{\circ}$ C
Velocity input command	. \pm 10V
Output ripple frequency (\pm 15%)	.20 kHz
Feedback	.Brushless resolver
Tachometer gradients (switch selectable) (\pm 2.5%)	.1 V/kRPM, 8000 RPM max. .2 V/kRPM, 4000 RPM max. .4 V/kRPM, 2000 RPM max. .8 V/kRPM, 1000 RPM max.
Tachometer ripple (max.)	
Drive only	.3% p-p
With standard PacSci motor	.5% p-p
Encoder output resolutions (switch selectable)	
Standard	.500, 512, 1000, 1024 PPR, \pm 22 arcmin accuracy
Optional (3000 RPM max. speed)	.2048, 4096 PPR, \pm 4 arcmin accuracy
Control inputs	.Enable .Reset .Inhibit + .Inhibit -
Test points (front panel)	.Velocity command .Tach monitor .Current command .Current monitor .Commutation signal
Fault output	.3 bit fault code, open collector
Digital Personality Module communications	.9600 baud
Interfacing connectors (furnished)	.All plug-in mating connectors
Storage temperature	-.55 $^{\circ}$ C to 70 $^{\circ}$ C
Operating temperature	
Full ratings	.0 $^{\circ}$ C to 50 $^{\circ}$ C
Derated Δ	.50 $^{\circ}$ C to 60 $^{\circ}$ C
Altitude	.5000 ft. (1500 m)
Humidity	.10% to 90%, non-condensing
Weight	.SC722, 13 lbs. .SC723, 16 lbs. .SC724/725, 40 lbs. .SC726, 90 lbs.

Δ Linearly derate the continuous current and power ratings to 70% at 60 $^{\circ}$ C.
 Δ With "B" version of drive, line count less than 2048 is not available.

POWER DATA . . . SC720 Series Controllers

	SC722	SC723	SC724	SC725	SC726
Input voltage	90 to 264 Vac, 47 to 63 Hz, 1 phase				
Control logic power	120 Vac (+10%, -15%)/ 240 Vac (+10%, -15%), 47 to 63 Hz, 1 or 3 phase				
Bus power	240 Vac (+ 10%, -15%), 47 to 63 Hz, 3 phase				
Bus Voltage	320 Vdc				
(with 240 Vac input)	160 Vdc				
(with 120 Vac input)					
Input current Δ	500 mA max. @ 120 Vac, 250 mA max. @ 240 Vac.				
Control logic power					
Bus current (RMS)					
(240 Vac, 3-phase)	4.5 A _{rms}	9 A _{rms}	18 A _{rms}	29 A _{rms} (@6kW)	38 A _{rms} (@12kW)
Output current @ 50$^{\circ}$C Δ					
Peak (5 seconds)	7.5 A	15 A	30 A	60 A	120 A
Continuous (stall)	3.8 A	7.5 A	15 A	30 A Δ	60 A
Output power (min. @ 50$^{\circ}$C)					
Peak (5 seconds)					
240 Vac, 3-phase	2.2 kW	4.5 kW	9 kW	18 kW	36kW
240 Vac, 1-phase	2.0 kW	4.0 kW	n/a	n/a	n/a
Continuous					
240 Vac, 3-phase	1.1 kW	2.2 kW	4.5 kW	9 kW	18 kW
240 Vac, 1-phase	0.8 kW	1.6 kW	n/a	n/a	n/a
Shunt regulator power					
Peak	3 kW	6 kW	20 kW	20 kW	40 kW
Continuous	20 W	40 W	200 W	200 W	500 W

Δ Currents ratings are defined as the maximum value of a 6-step waveform.
 Δ The SC725 can be configured for 40 A continuous (stall).

Δ Input current is specified with unit operating at continuous rated output power.

SC720 SERIES RECOMMENDED MOTOR/CONTROLLER SYSTEMS [△]*

Peak stall torque T_{PS} [△] lb-in./Nm	Peak rated torque T_{PR} [△] lb-in./Nm	Cont. stall torque T_{CS} lb-in./Nm	Cont. rated torque T_{CR} lb-in./Nm	Rated Speed W_r [△] rpm	Inertia I [△] lb-in-S ² / kgm ²	Servo-motor Dia. or Width/height inch/mm	Servo-motor Length inch/mm	Inductance line-line L mH	Servo-motor model	Servo-Controller model [△]
---	---	---	---	--	---	---	----------------------------------	------------------------------------	----------------------	--

With R Series (low inertia, rare earth magnet) motors

10/ 1.1	6.5/ .7	4.8/ .5	2.5/ .3	8000	0.12/ .014	2.00/ 50.8	7.38/187.5	5.3	R22HENA-R1-NS-NV-01	SC722A-001-PM72005
14/ 1.6	8/ .9	7.6/ .9	5.2/ .6	8000	0.15/ .017	2.00/ 50.8	8.38/212.9	6.5	R23HENA-R1-NS-NV-01	SC722A-001-PM72004
17/ 1.9	10/ 1.1	9.2/ 1.0	7.1/ .8	6000	0.18/ .020	2.00/ 50.8	9.38/238.3	6.5	R24HENA-R1-NS-NV-01	SC722A-001-PM72004
27/ 3.0	25/ 2.8	14/ 1.6	10/ 1.1	4000	0.55/ .062	3.25/ 82.6	7.09/180.1	23.0	R32GENC-R2-NS-NV-00	SC722A-001-PM72008
27/ 3.0	25/ 2.8	14/ 1.6	6/ .7	7000	0.55/ .062	3.25/ 82.6	7.09/180.1	5.8	R32HENC-R2-NS-NV-00	SC723A-001-PM72004
36/ 4.0	33/ 3.7	21/ 2.4	16/ 1.8	3000	0.74/ .084	3.25/ 82.6	8.09/205.5	22.0	R33GENC-R2-NS-NV-00	SC722A-001-PM72008
36/ 4.0	25/ 2.8	21/ 2.4	10/ 1.1	6000	0.74/ .084	3.25/ 82.6	8.09/205.5	5.6	R33HENC-R2-NS-NV-00	SC723A-001-PM72004
45/ 5.0	42/ 4.7	27/ 3.0	24/ 2.7	2800	0.92/ .104	3.25/ 82.6	9.09/230.9	30.0	R34JENC-R2-NS-NV-00	SC722A-001-PM72012
45/ 5.0	38/ 4.3	27/ 3.0	16/ 1.8	4000	0.92/ .104	3.25/ 82.6	9.09/230.9	7.5	R34KENC-R2-NS-NV-00	SC723A-001-PM72008
54/ 6.0	53/ 5.9	32/ 3.6	30/ 3.4	2000	1.11/ .125	3.25/ 82.6	10.09/256.3	42.0	R35JENC-R2-NS-NV-00	SC722A-001-PM72012
54/ 6.0	48/ 5.4	32/ 3.6	23/ 2.6	3000	1.11/ .125	3.25/ 82.6	10.09/256.3	10.5	R35KENC-R2-NS-NV-00	SC723A-001-PM72008
66/ 7.4	50/ 5.6	33/ 3.7	33/ 3.4	1800	1.90/ .215	4.25/108.0	8.34/211.8	53.0	R43GENA-R2-NS-NV-00	SC722A-001-PM72012
66/ 7.4	60/ 6.7	33/ 3.7	31/ 3.5	3000	1.90/ .215	4.25/108.0	8.34/211.8	13.3	R43HENA-R2-NS-NV-00	SC723A-001-PM72008
106/11.9	95/10.6	48/ 5.4	46/ 5.2	2000	2.70/ .305	4.25/108.0	9.84/249.9	4.9	R45GENA-R2-NS-NV-00	SC723A-001-PM72012
106/11.9	95/10.6	48/ 5.4	43/ 4.8	4000	2.70/ .305	4.25/108.0	9.84/249.9	20.0	R45HENA-R2-NS-NV-00	SC724A-001-PM72012
142/15.9	120/13.4	64/ 7.2	61/ 6.8	1500	3.50/ .395	4.25/108.0	11.34/288.1	25.0	R46GENA-R2-NS-NV-00	SC723A-001-PM72012
142/15.9	120/13.4	64/ 7.2	50/ 5.6	3000	3.50/ .395	4.25/108.0	11.34/288.1	6.2	R46HENA-R2-NS-NV-00	SC724A-001-PM72008
150/16.8	125/14.0	70/ 7.8	58/ 6.5	3000	7.10/ .818	5.75/146.1	9.36/237.7	8.9	R63GENA-R2-NS-NV-00	SC724A-001-PM72007
150/16.8	142/15.9	70/ 7.8	38/ 4.3	6000	7.10/ .818	5.75/146.1	9.36/237.7	2.2	R63HENA-R2-NS-NV-00	SC725A-001-PM72003
240/26.9	230/25.8	115/12.9	102/11.4	1700	11.10/1.28	5.75/146.1	11.36/288.5	13.7	R65GENA-R2-NS-NV-00	SC724A-001-PM72012
240/26.9	200/22.4	115/12.9	90/10.1	3000	11.10/1.28	5.75/146.1	11.36/288.5	3.4	R65HENA-R2-NS-NV-00	SC725A-001-PM72008
340/38.1	305/34.2	168/18.8	156/17.5	1000	15.10/1.74	5.75/146.1	13.36/339.3	18.2	R67GENA-R2-NS-NV-00	SC724A-001-PM72016
340/38.1	330/37.0	168/18.8	146/16.4	2000	15.10/1.74	5.75/146.1	13.36/339.3	4.6	R67HENA-R2-NS-NV-00	SC725A-001-PM72012
300/33.6	280/31.4	190/21.3	125/14.0	3800	39.10/4.50	7.50/190.5	10.93/277.6	3.2	R84GENA-R2-NS-NV-00	SC725A-001-PM72008
300/33.6	270/30.2	190/21.3	45/ 5.0	6000	39.10/4.50	7.50/190.5	10.93/277.6	0.8	R84HENA-R2-NS-NV-00	SC726A-001-PM72004
410/45.9	395/44.2	276/30.1	225/25.2	2000	58.10/6.69	7.50/190.5	12.93/328.4	3.6	R86GENA-R2-NS-NV-00	SC725A-001-PM72012
410/45.9	365/40.9	276/30.1	120/13.4	4000	58.10/6.69	7.50/190.5	12.93/328.4	0.9	R86HENA-R2-NS-NV-00	SC726A-001-PM2009
540/60.5	525/58.8	357/28.8	325/36.4	1500	76.10/8.77	7.50/190.5	14.93/379.2	4.0	R88GENA-R2-NS-NV-00	SC725A-001-PM72012
540/60.5	500/56.0	357/28.8	205/23.0	3000	76.10/8.77	7.50/190.5	14.93/379.2	1.0	R88HENA-R2-NS-NV-00	SC726A-001-PM72009
800/89.6	730/81.8	451/50.5	424/47.5	1200	95.10/10.96	7.50/190.5	16.93/430.0	7.4	R8AGENA-R2-NS-NV-00	SC725A-001-PM72016
800/89.6	720/80.6	451/50.5	300/33.6	2000	95.10/10.96	7.50/190.5	16.93/430.0	1.9	R8AHENA-R2-NS-NV-00	SC726A-001-PM72013

With F Series (medium inertia, ferrite magnet) motors [△]

56/ 6.3	34/ 3.8	32/ 3.6	25/ 2.8	1500	9.20/1.04	4.25/108.0	8.34/211.8	49.0	F43GENA-R2-NS-NV-00	SC722A-001-PM72032
60/ 6.7	30/ 3.4	32/ 3.6	22/ 2.5	3000	9.20/1.04	4.25/108.0	8.34/211.8	12.0	F43HENA-R2-NS-NV-00	SC723A-001-PM72028
84/ 9.4	55/ 6.2	46/ 5.2	43/ 4.8	1000	13.70/1.55	4.25/108.0	9.84/249.9	69.0	F45FENA-R2-NS-NV-00	SC722A-001-PM72036
84/ 9.4	45/ 5.0	46/ 5.2	38/ 4.3	2000	13.70/1.55	4.25/108.0	9.84/249.9	17.0	F45GENA-R2-NS-NV-00	SC723A-001-PM72032
121/13.6	62/ 6.9	61/ 6.8	48/ 5.4	1500	17.70/2.00	4.25/108.0	11.34/288.1	24.0	F46GENA-R2-NS-NV-00	SC723A-001-PM72032
121/13.6	60/ 6.7	61/ 6.8	43/ 4.8	3000	17.70/2.00	4.25/108.0	11.34/288.1	6.0	F46HENA-R2-NS-NV-00	SC724A-001-PM72028

[△] See page B-73 for definitions of ratings.

[△] Peak torque ratings are for 5 seconds

[△] Rated speeds are for 240 Vac, 3 phase operation.
Derate to approximately 85% for 240 Vac, 1 phase operation.
Derate to 40% for 120 Vac, 1 phase operation.

[△] Includes primary feedback inertia.

[△] Controller model numbers are for 12 bit resolution option. See How to Order, page B-53.

[△] Each system requires one feedback and one motor power cable. See Section D for more information.

*See pages B-6 through B-26 for information on the next generation Servo Position Control.

CONNECTION DIAGRAM. . . SC720 Series Controllers*

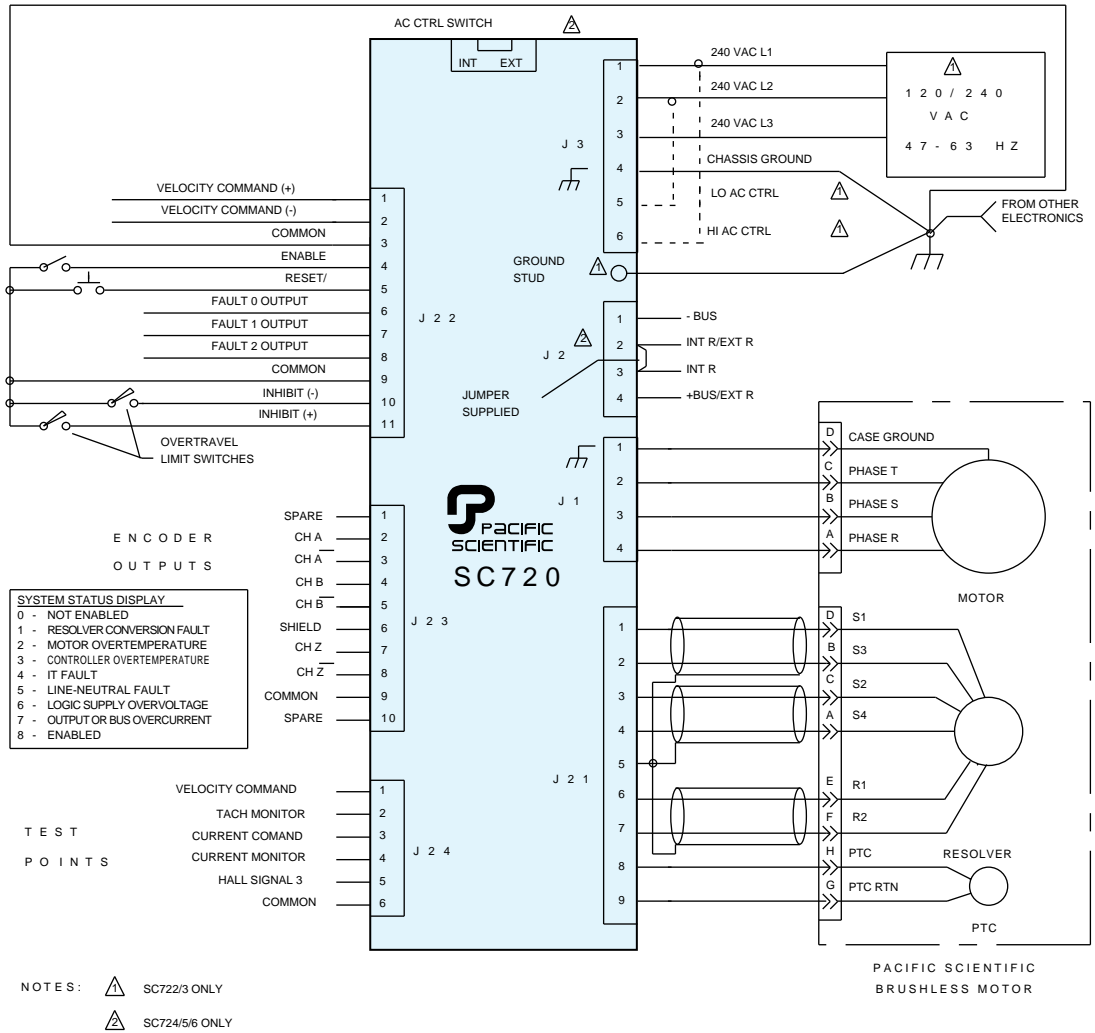

*See pages B-6 through B-26 for information on the next generation Servo Position Control.

HOW TO ORDER . . .SC720 Series Controllers*

SC720 Series servo controllers must be used with the appropriate personality module. Since the personality module is dependent on the specific motor used, a factory code is assigned.

To find the appropriate personality module model number, refer to the Recommended Motor/Controller Systems table on page B-51.

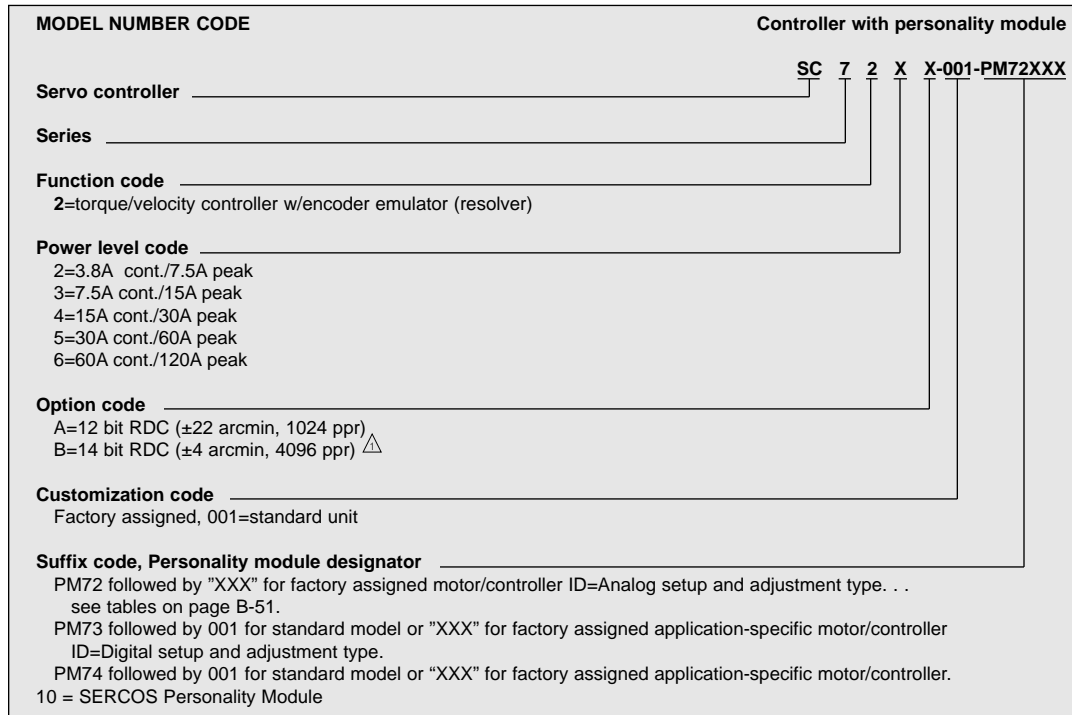

HOW TO ORDER...SC720 Series Recommended Motor/Controller Systems

See the Recommended Motor/Controller Systems table on page B-51 for performance information and model numbers for servo motor/controller combinations. Order motors and controllers as separate part numbers. See brushless servo motor section for additional motor specifications and information.

\triangle SERCOS Personality Module not available with this option.

*See pages B-6 through B-26 for information on the next generation Servo Position Control.

SC720 SERIES*

PERSONALITY MODULES

Personality modules contain all motor and application-specific drive settings and parameters. Easily removed and installed from the front of the drive, these modules simplify setup, installation and maintenance while reducing spares requirements.

ANALOG PERSONALITY MODULE (APM)

Drives with analog personality modules are designed for use in conventional multi-axis systems utilizing $\pm 10V$ analog velocity or torque commands and quadrature encoder position feedback. This module provides analog command of motor shaft torque or velocity. Application and motor parameters are set in the module using DIP switches, jumpers, and potentiometers. Additional parameter adjustments can be implemented as factory options. The module contains:

- Compensation potentiometers for:
 - velocity offset
 - command gain
 - loop gain
 - current limit
- Switch settings for:
 - tachometer scaling for velocity loop
 - velocity or torque block selection
 - encoder line count selection
 - four or eight motor-pole selection
- Velocity loop compensation range jumper selection
- Anti-resonance low pass filter time constant jumper selection
- Spare jumper positions for adding components for non-standard compensation

In these systems, the position loop is generally closed in a motion control card while the drive closes the velocity and current loops. In some instances, the position and velocity loops are closed in the motion control card and only the current loop is closed in the drive. The motion profile planning and generation is done in the motion control card.

HOW TO ORDER SC720 SERIES DRIVES WITH AN ANALOG PERSONALITY MODULE (APM)

The SC720 drives must be used with a personality module. Since the personality module is dependent on the specific motor used, a factory code is assigned. To find the specific drive/APM combination, refer to the Recommended Motor/Controller Systems table on page B-51. The analog personality module designation is suffix number added to the ServoDrive model. PM72XXX is the suffix for the SC720 drives. For example, a SC722A-001-PM72005 is the correct drive/APM to order for use with the R22HENA-R1-NS-NV-01 servo motor. The drive/APM, motor and cabling are ordered as separate part numbers.

Place orders through your nearest Pacific Scientific Motion Control Distributor or call the factory direct for assistance in placing an order.

DIGITAL PERSONALITY MODULE (DPM)

Drives with digital personality modules are for multi-axis systems utilizing $\pm 10V$ velocity or torque commands and quadrature encoder position feedback. All adjustments on this module are set by a computer over a serial communications port and stored in EEPROM. Combined with DPM Dialogue™, a menu driven software support package which runs on your IBM PC or PC clone, this module provides the same modes as the analog module plus digital position commands in step and direction or quadrature format. These commands may be used for electronic gearing or come from an indexer for position profiling or multi-axis control. The module also features automated setup of adjustments and the ability to change adjustment settings via the serial port while the drive is operating. The module contains:

- All digital setup of the current loop, velocity loop and (when utilized) position loop. There are no pots, DIP switches, plug-on jumpers or components to alter when setting up the servo loops. All parameters are downloaded using an RS-232 or RS-485 port and can be saved in non-volatile memory.
- Automatic drive setup using DPM Dialogue.
- Simplified uploading, downloading, and disk storage of DPM parameters for easy cloning and backup documentation.
- Follower operation in electronic gearing applications.
- Position control using Step and Direction inputs. This means that your SC720 may be driven directly from most stepper indexers.
- Precise readout of motor velocity and position using the serial link and DPM Dialogue.

In these systems, the position loop is generally closed in a motion control card while the drive closes the velocity and current loops. In some instances, the position and velocity loops are closed in the motion control card and only the current loop is closed in the drive. The motion profile planning and generation is done in the motion control card.

Drives with these modules can also be used in multi-axis systems utilizing a stepper indexer which supports Step and Direction outputs. In these systems, the position loop is closed in the drive/DPM along with the velocity and current loop. The motion profile planning and generation is done in the stepper indexer.

This module also allows the drive to be used as a follower axis in electronic gearing applications. In these systems, the position loop is closed in the drive/DPM along with the velocity and current loop.

The SC720 drives generate quadrature encoder feedback signals from the motor's resolver. These quadrature encoder signals are used by the motion control card to close the system's position loop and to execute the motion profiles. In systems utilizing a stepper indexer for motion control, the encoder feedback signals may or may not be used by the indexer for position verification or closure of the position loop. In electronic gearing applications, these encoder feedback signals may be used to command a follower axis.

Application and motor parameters are set on this module (which is a plug in unit) for easy installation and maintenance. Parameters are all set via the modules serial port using the DPM Dialogue program supplied with the module.

*See pages B-6 through B-26 for information on the next generation Servo Position Control.

HOW TO ORDER SC720 SERIES DRIVES WITH A DIGITAL PERSONALITY MODULE (DPM) (Cont.)

The SC720 drives must be used with a personality module. The digital personality module designation is a suffix added to the servo controller model number. PM73001 is the suffix for the SC720 drives. For example, an SC722A-001-PM73001 is the correct drive/DPM to order for use with the R22HENA-R1-NS-NV-01 servo motor. The DPMs will always be identified as PM73001 unless they are customer specific. In these cases, sequential numbers beyond 001 will indicate a special set up for a special motor via the DPM Dialogue database.

The drive, DPM, motor and cabling are ordered as separate part numbers.

Place orders through your nearest Pacific Scientific Motion Control Distributor or call the factory direct for assistance in placing an order.

SERCOS PERSONALITY MODULE (SPM)

Drives with SERCOS personality modules are designed for use in distributed, multi-axis motion control systems utilizing the SERCOS (**S**erial **R**ealtime **C**ommunications **S**ystem) digital interface International standard. SERCOS replaces the ± 10 volt analog servo command interface with a high speed, digital, fiber optic communications link. SERCOS is the only open, fiber optic communications system with the high speed performance required to link machine controllers with multiple digital drives. The SERCOS standard allows the control to command position, velocity, or torque of the motor/drive via the fiber optic ring. The SERCOS ring also supports the flow of information from the drive back to the control. Actual motor position, velocity, torque and drive status are examples of the information which the control can obtain from the drive. The benefits of SERCOS technology are:

- Open system specification
- Significantly reduced installed system cost
- Reliable noise free environment using fiber optics
- Superior 32-bit performance

The SERCOS module contains all the hardware and software necessary to connect the SC720 Series drives as slaves on the SERCOS fiber optic ring. This allows the drives to be used as components in state-of-the-art multi-axis motion control systems. Application and motor parameters are set on the personality module via the SERCOS fiber optic ring using the drive set-up program supplied with the SERCOS control.

A single fiber optic cable ring is the only connection necessary between the control and the drives. This reduces installation costs and simplifies design and maintenance. This single cable not only provides command information to all the drives but also provides drive status information to the control. This allows the control to act on drive status information and make this information available to the machine operator.

A SERCOS based system offers many benefits over a conventional centralized multi-axis control system,

especially in applications where motors and drives are not conveniently located in a central location. The fiber optic network eliminates noise and ground loop problems thereby easing installation and maintenance. This module:

- Offers compatibility with the SERCOS digital interface international standard for digital servo drives.
- Provides a communications interface so that up to 32 SC720 servo drives can be controlled by a SERCOS master across a single fiber optic ring. For applications requiring more than 32 axes, additional SERCOS rings may be configured and synchronized from the SERCOS master.
- Eliminates costly and difficult to install low voltage signal wiring associated with conventional analog servo interfaces.
- Provides 100% electrical isolation between motion controller (SERCOS master) and servo drive subsystem through the use of fiber optics.
- Supports SERCOS telegram cycle time of 2 milliseconds in either the position or velocity control mode.

The SERCOS topology takes advantage of processing power resident in the drives. Microprocessors and/or DSPs in the drive handle the processor intensive tasks of closing the position, velocity, and current loops. In the distributed topology, processor power is matched to the complexity level of the application. As the axis count of the system increases, processor power is incrementally added automatically with the addition of each drive. In the centralized topology, these processor intensive servo loop closure tasks must be handled by the central controller. This central control must possess the processor power to handle the worst case system. In many instances, there will be unused (and costly) processor power.

Servo loop closures must be done at fairly high update rates to achieve good performance. For the distributed SERCOS system, this is done in the drive by its internal processor. The SERCOS controller is freed from this burden and its processor is dedicated to running the user's motion control program and doing the generation of motion profiles. Motion profiles are updated every 2 mS by the SERCOS controller and transmitted to the SERCOS compatible drives on the fiber optic ring. Up to 16 drives can have their position updated at this 2 mS rate.

This 2 mS profile generator update rate should not be confused with the servo loop closure update rates. Servo loop updates occur at a faster rate within the drive's local processor. In traditional centralized systems, this profile generator update rate is typically not specified since this interface is buried within the controller.

In a typical industrial machine, position loop response is 20 Hz maximum because of mechanical limitations. A 20 Hz position loop has an 8 mS response time. The position command to the drive is being updated every 2 mS. The drive interpolates these 2 mS position updates at a 0.5 mS rate. Both the position command update and the interpolation between these updates are occurring at rates significantly faster than those required by the mechanical system. This illustrates that a 2 mS position profile update is sufficiently fast for a vast majority of applications. In instances where there are fewer than 16 drives on the ring, the update time can be decreased. For example, 8 drives on a ring can be updated at 1 mS or 4 drives on a ring can be updated at 0.5 mS.

HOW SERCOS WORKS-AN OVERVIEW

The SERCOS interface is implemented using a master-slave configuration, interconnected unidirectionally over a fiber optic cable, in a ring structure. The data transfer rate is 4 Mbits/s with an update time of 2 msec.

The Pacific Scientific/Automation Intelligence programmable motion controller (or similar controller) is the master and the brushless drives with SERCOS personality modules are the slaves. The motion controller controls the flow of information by sending out a synchronization "heartbeat" called the MST every 2 msec. See Figure B-5. All the slaves sequentially receive the MST.

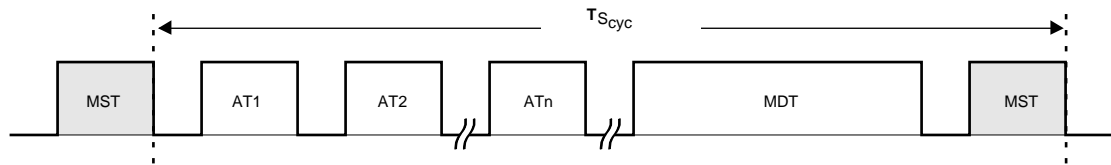

Figure B-5. SERCOS Master Synchronization Telegram-MST

The drives internally synchronize themselves to the MST clock and send back current drive information to the master during "time slot" intervals. This current drive information is contained in the Amplifier Telegram, or AT. (See Figure B-6). The AT is configurable, although it typically consists of time-critical data such as actual position, velocity and torque.

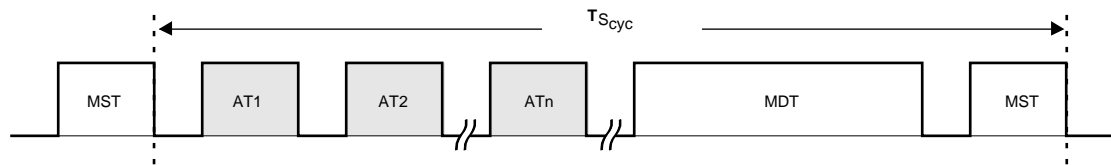

Figure B-6. SERCOS Amplifier Telegram-AT

At the end of each cycle, a Master Data Telegram, or MDT is sent to the slaves. See Figure B-7. The new command values for each drive on the ring are contained in this MDT.

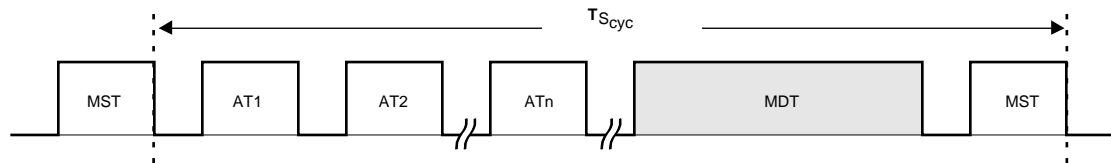

Figure B-7. Master Data Telegram-MDT

IDENTIFICATION NUMBERS (IDN)

- All parameters defined as IDNs
 - 32-bit integers
 - Lists of other IDNs
 - 16-bit Words
 - Text
- IDN Definition Includes
 - Value
 - Description
 - Attributes
 - Min, Max
 - Units
- The SERCOS Personality Module supports the following IDNs as defined by the SERCOS standard. The SERCOS host controller and its software allow setting and reading of these IDNs.
 - 1 Control Unit Cycle Time (TNcvc)
 - 2 SYSTEM Interface Cycle Time (Tscvc)
 - 3 Minimum AT Transmit Starting Time (Tlmin)
 - 4 Transmit/Receive Transition Time (TATMT)
 - 5 Minimum Feedback Acquisition Time (T4min)
 - 6 AT Transmission Starting Time (TI)
 - 7 Feedback Acquisition Starting Time (T4)
 - 8 Command Valid Time (T3)
 - 9 Beginning Address in Master Data Telegram
 - 10 Length of Master Data Telegram
 - 11 Class 1 Diagnostics
 - 14 Interface Status
 - 15 Telegram Type Parameter
 - 16 Custom Amplifier Telegram Configuration List
 - 17 IDN List of all Operation Data
 - 24 Configuration List of the Master Data Telegram
 - 32 Primary Mode of Operation
 - 40 Velocity Feedback Value
 - 41 Homing Velocity
 - 42 Homing Acceleration
 - 43 Velocity Polarity Parameter
 - 44 Scaling of Velocity Data
 - 45 Scaling Factor for Velocity Data
 - 46 Scaling Exponent for Velocity Data
 - 47 Position Command Value
 - 51 Position Feedback Value 1 (Motor Feedback)
 - 52 Actual Position Feedback 1-Reference Distance
 - 55 Position Polarity Parameters
 - 76 Position Data Scaling Method
 - 77 Linear Position Data Scaling Factor
 - 78 Linear Position Data Scaling Factor Exponent
 - 79 Rotational Position Resolution
 - 88 Receive to Receive Recovery Time (TMTSY)
 - 89 MDT Transmit Starting Time (T2)
 - 90 Command Value Transmit Time (TMTSG)
 - 95 Diagnostic Message
 - 99 Reset Class 1 Diagnostics
 - 103 Modulo Value

- 108 Feedrate Override
- 123 Feed Constant
- 127 Communications Phase 3 Transition Check
- 128 Communications Phase 4 Transition Check
- 130 Actual Position Value Probe 1 Positive Edge
- 131 Actual Position Value Probe 1 Negative Edge
- 138 Bipolar Acceleration
- 147 Homing Parameter
- 148 Drive-Controlled Homing Procedure Command
- 160 Scaling Method for Acceleration Data
- 161 Scaling Factor for Acceleration Data
- 162 Scaling Exponent for Acceleration Data
- 169 Probe Control Parameter
- 170 Probing Cycle Procedure Command
- 185 Length of the Configurable Data Record in the AT
- 186 List of the Configurable Data Record in the MDT
- 187 List of the Configurable data in the AT
- 188 List of the Configurable data in the MDT
- 301 Allocation of Real-Time Control Bit 1
- 303 Allocation of Real-Time Control Bit 2
- 305 Allocation of Real-Time Status Bit 1
- 307 Allocation of Real-Time Status Bit 2
- 400 Home Switch
- 401 Probe 1
- 403 Position Feedback Value Status
- 405 Probe 1 Enabled
- 409 Probe 1 Positive Latched
- 410 Probe 1 Negative Latched

DIAGNOSTIC DATA

In addition to the real-time transmission between the control and drives, SERCOS also provides advanced diagnostic and fault information on the same fiber optic cable. Non time-critical data such as set up parameters, tuning coefficients and homing functions are available through the SERCOS service channel without connecting to any additional I/O. Also incorporated is an oscilloscope function that digitally captures and stores noise-free torque, velocity and position samples for later analysis.

GENERAL MOTION CONTROL

SERCOS was originally developed for machine tool applications. Later, SERCOS has evolved for general motion control and can control typical requirements such as:

- Point-to-point moves
- Electronic gearing
- Electronic CAM profiles
- Registration
- Measurements
- Electronic drive trains

USER CONNECTIONS

- On SERCOS Personality Module
 - J41 Front Panel Cross Connect Cable. This connector is used with the Pacific Scientific supplied cable to connect the SPM to the host servo drive (SC720 Series) J22 front panel connector. The following signals are brought across on this cable:
 - ENABLE
 - RESET
 - INHIBIT+
 - INHIBIT-
 - FAULT0
 - FAULT1
 - FAULT2
- On Host Servo Drive
 - J21 Resolver Feedback and Motor PTC
 - J22 Front Panel Cross Connect to SPM (goes to J41 on SPM)
 - J23 Encoder Emulation Outputs plus **PROBE** and **HOME**
 - J23-1 PROBE Input
 - J23-10 HOME Input
 - J24 Test Points plus **USER ENABLE**
 - J24-1 USER ENABLE Input
 - J1 AC Power
 - J2 Motor Power

ADDRESS SELECTION DIP SWITCH

- Eight switches used for selecting the SPM SERCOS address. Each servo drive on the SERCOS ring must be assigned a unique address.

HOW TO ORDER SC720 SERIES DRIVES WITH A SERCOS PERSONALITY MODULE (SPM)

For an SPM, PM74001 is the suffix for the SC720 drives. For example, an SC722A-001-PM74001 is the correct drive/DPM to order for use with the R22HENA-R1-NS-NV-01 servo motor. The drive/SPM, motor and cabling are ordered as separate part numbers.

SERCOS—QUESTIONS AND ANSWERS

What is SERCOS?

SERCOS (**SE**rial **R**eal-time **CO**munication **S**ystem) is an open fiber optic based controller to digital drive interface international standard. The SERCOS interface is designed to communicate closed loop data serially in real time for high performance motion control systems.

Why a digital standard?

Today, the purely digital drive system is becoming more prevalent. The digital servo drive has no analog circuits and uses no analog feedback loops. Incorporating low cost, high-performance digital signal processors (DSPs), this technology offers enhanced capability well beyond analog drives. But to fully exploit its potential, a well-defined and standardized digital interface must also be specified. The reason is that if a digital motion controller must control a digital drive, through an analog signal, resolution is sacrificed and noise sensitivity becomes an issue. Even if both digital units operate internally with numerical precision of 32 bits, A/D and D/A conversion typically occurs only at 12 to 16-bits, introducing electrical noise and thereby limiting the full capabilities of the drive.

What are the advantages of an open interface?

Proprietary, vendor specific digital interfaces have existed since the 1980s. However, they restrict the user to a single source for both drives and control. This limits the user's ability to select components based on application need and creates a substantial support burden when equipment from various suppliers must be maintained. Obviously, the motion control industry is best served in the long run by an open interface specification.

Who developed the standard?

SERCOS was initiated in 1987 by a group of European machine builders who were concerned about the impending problems of multiple digital interfaces. One of the stated goals of SERCOS is to ensure that the exchange of data required for utilizing digital drives does not obstruct individual development of drives and controls. It was developed jointly by the German Machine Tool Builders Association and the German Electrical and Electronic Manufacturers Association. These two associations have assembled major manufacturers of motors, drives and CNCs into a joint working group. Companies who have joined in the SERCOS working group include Pacific Scientific/Automation Intelligence, AEG, ABB, AMK, Baumuller, Bosch, Indramat, and Siemens.

How is SERCOS implemented?

The transmission medium is plastic fiber optic cable, implemented in a fiber optic ring currently running at 4 MB/s. The current SERCOS implementation permits up to 32 drives to be connected to one fiber optic ring with a position profile update time of 2 ms. The topology is a ring structure in which MASTER and SLAVES are connected unidirectionally. The MASTER controls and synchronizes the ring and a SLAVE can service one or multiple drives.

What about cost?

At the end of 1993, a SERCOS application specific integrated circuit (ASIC) was introduced. It simplifies product designs incorporating the SERCOS interface by handling the low-level protocol SERCOS communication link. The host control writes to a dual-port RAM in the ASIC, which then handles messaging, timing, and communications with the drives. The use of the ASIC raises the data transfer rate to 4 Mbits/s and reduces the per node cost of the interface. Calculations show that the costs for a SERCOS interface correspond to those of an analog interface for the same drive. There are significant savings with respect to the controls, since a number of drives can be connected to each SERCOS interface.

What are other advantages?

Beyond the obvious advantages of an open digital interface, the physical implementation is simple to install and maintain and will operate reliably in the factory environment with up to a 100m interconnection path between units.

The immense requirements for conduit, wiring and terminations, which are normally associated with an analog interface, are eliminated with SERCOS. So are the long manhour requirements typically associated with installing an analog interface. The fiber itself is the sole connection between the controller and the drives. Since everything runs along a single fiber network, cable and termination cost is virtually non-existent. In fact, fiber's inherent noise immunity means that it can even run in the same conduit that carries high voltage enabling.

Is SERCOS close to adoption?

The Draft International Standard (DIS) has been submitted to the IEC. It is expected to be published as an international standard soon.

Is SERCOS just for machine tool/CNC applications?

Although originally envisioned and developed as a CNC to digital drive interface, this specification has proven itself to be widely applicable as an interface between general motion controls and digital drives. Industry has come to realize that all the basic primitives of general motion control can be implemented in a SERCOS ring—opening up vast new market potential.

SERCOS can be used effectively and efficiently to implement the following classes of general motion control functions:

- Point-to-Point Moves
- Electronic Gearing
- Electronic Cam Profiling
- Registration/Measurement
- Electronic Drive Trains

Where is SERCOS Specification headed?

Recently, industry has come to realize that all the basic primitives of general motion control can be implemented in a SERCOS ring, dispelling the myth that SERCOS is a viable standard only for CNC and machine tools. Numerous servo drive manufacturers have products either on the market or under development. With ASIC availability and IEC standardization, the technology will become more widely accepted in the motion control industry.



SC400 SERIES

Peak torque range:
27 to 142 lb-in.
(3.0 to 16 Nm)

Analog Torque or Velocity Controllers 350 W to 2.2 kW continuous power; 1 kW to 4.5 kW peak

- Ideal for use with your position controller
- 120 Vac or 240 Vac operation
- Inaudible, high frequency PWM current control
- Easy analog interfacing
- Optional clutch brake style interface
- Panel mount
- Integral power supply
- UL and ETL Recognition

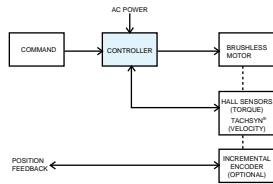

SC400 Series controllers provide economical analog torque/velocity control of low to medium power brushless servo motors.

Two models provide continuous rated torques ranging from 10.1 lb-in. to 61 lb-in. and peak rated torques ranging from 25 lb-in. to 120 lb-in. when used in combination with Pacific Scientific brushless servo motors.

COMPACT AND RELIABLE PERFORMANCE

Each is a stand-alone, 4-quadrant controller with integral power supply. Derotated current loop control contributes to high speed performance.

SC400 controllers feature insulated gate bipolar transistor (IGBT) output stages. A proprietary custom integrated circuit performs processing for system protection and motor commutation control. Both contribute to increased reliability, while reducing unit cost and package size.

Commutation and velocity control signals are derived from a single Tachsyn® feedback device. Pacific Scientific rare earth brushless servo motors are available with high reliability Tachsyn transducers for velocity control and Hall sensors for torque control.

OPERATING FEATURES

- Smooth, high bandwidth velocity control
- Derotated 6-step current loop
- Transformerless, direct 240/120 Vac line operation
- Convection cooled
- IGBT PWM output stage

DIMENSIONS in. (metric dimensions mm for ref. only)

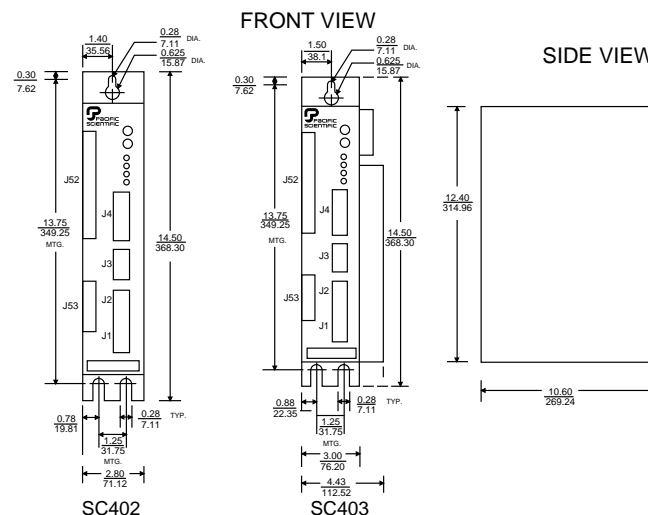

ADJUSTMENTS

- Velocity loop gain
- Velocity command gain
- Velocity offset
- Current limit
- Selection jumpers:
Velocity/torque control select
2 velocity compensation networks
1 user installable compensation network

PROTECTION/DIAGNOSTICS

- Inrush current limiting
- MOV protected output
- Output short circuit protection
- Controller overtemperature shutdown
- Motor overtemperature sensor input
- Fully fused



SC402 Controller
is UL Recognized
(File E137798)

GENERAL. . .SC400 Series Controllers

Efficiency (@ rated continuous power)	> 90%
Form factor	< 1.01
Current loop bandwidth	3 kHz max.
Velocity offset	adjustable to zero
Velocity offset drift (referred to input)	.50 $\mu\text{V}/^\circ\text{C}$ typical
Velocity input command	$\pm 10\text{V}$
Output ripple frequency	.20 kHz (SC402) or 15 kHz (SC403)
Fault output	open collector, 30 Vdc, 25 mA sink
Operating temperature	
Full ratings	.0°C to 50°C
Derated Δ	.50°C to 60°C
Storage temperature	-55°C to 70°C
Humidity	10% to 90%, non-condensing
Altitude	.5000 feet (1500 meters)
Δ Linearly derate the continuous current and power ratings to 70% at 60°C.	

POWER DATA. . .SC400 Series Controllers

	SC402	SC403
Input voltage	120/240 Vac (+10%, -15%); 1- or 3-phase; 47-63 Hz	
Input currentΔ		
240 Vac, 3-phase input	4.2 A _{rms}	8.9 A _{rms}
240 Vac, 1-phase input	5.8 A _{rms}	12.4 A _{rms}
120 Vac, 1-phase input	5.8 A _{rms}	12.4 A _{rms}
Bus voltage (nominal)		
240 Vac models	320 Vdc	320 Vdc
120 Vac models	160 Vdc	160 Vdc
Output currentΔ		
Peak	7.0A	15.0A
Continuous (stall)		
240 Vac models	3.5A	7.5A
120 Vac models	4.2A	7.5A
Output power		
Peak		
240 Vac input	2000W	4500W
120 Vac input	1000W	2250W
Continuous		
240 Vac, 3-phase input	1000W	2250W
240 Vac, 1-phase input	700W	1575W
120 Vac, 1-phase input	350W	800W
Shunt regulator		
Peak power	3000W	6000W
Continuous power	20W	40W

- Δ Input current is specified with unit operating at continuous rated output power.
 Δ Current ratings are defined as the maximum value of a 6-step waveform.

SC400 Series Recommended Motor/Controller Systems Δ

See performance curves beginning on page B-74.

Peak stall torque T_{PS} lb-in./Nm	Peak rated torque T_{PR} lb-in./Nm	Cont. stall torque T_{CS} lb-in./Nm	Cont. rated torque T_{CR} lb-in./Nm	Rated Speed W_R rpm	Inertia $x 10^{-3}$ lb-in-S ² / kgm ²	Servo motor Width/height inch/mm	Servo motor Length inch/mm	Inductance line-line L mH	Servo motor model	Servo-Controller model Δ
27/ 3.0	25/ 2.8	14/ 1.5	10/ 1.1	4000	0.46/ .052	3.25/ 82.6	7.09/180.1	23.0	R32GENC-TS-NS-NV-00	SC402-011-T3
28/ 3.1	25/ 2.8	14/ 1.5	6/ 0.7	7000	0.46/ .052	3.25/ 82.6	7.09/180.1	5.8	R32HENC-TS-NS-NV-00	SC403-012-T2
36/ 4.0	33/ 3.7	21/ 2.3	16/ 1.8	3000	0.65/ .074	3.25/ 82.6	8.09/205.5	22.0	R33GENC-TS-NS-NV-00	SC402-011-T3
39/ 4.3	25/ 2.8	21/ 2.3	10/ 1.1	6000	0.65/ .074	3.25/ 82.6	8.09/205.5	5.6	R33HENC-TS-NS-NV-00	SC403-012-T2
45/ 5.0	43/ 4.8	27/ 3.0	24/ 2.7	2800	0.83/ .094	3.25/ 82.6	9.09/230.9	30.0	R34JENC-TS-NS-NV-00	SC402-012-T4
48/ 5.3	38/ 4.2	27/ 3.0	16/ 1.8	4000	0.83/ .094	3.25/ 82.6	9.09/230.9	7.5	R34KENC-TS-NS-NV-00	SC403-012-T3
54/ 6.0	53/ 5.9	32/ 3.6	30/ 3.3	2000	1.02/ .115	3.25/ 82.6	10.09/256.3	42.0	R35JENC-TS-NS-NV-00	SC402-012-T4
59/ 6.6	48/ 5.3	32/ 3.6	23/ 2.5	3000	1.02/ .115	3.25/ 82.6	10.09/256.3	10.5	R35KENC-TS-NS-NV-00	SC403-002-T3
66/ 7.4	50/ 5.6	33/ 3.4	33/ 3.7	1800	1.81/ .205	4.25/108.0	8.34/211.8	53.0	R43GENA-TS-NS-NV-00	SC402-012-T4
71/ 7.9	66/ 7.4	33/ 3.4	31/ 3.4	3000	1.81/ .205	4.25/108.0	8.34/211.8	13.3	R43HENA-TS-NS-NV-00	SC403-002-T3
106/11.9	95/10.6	48/ 5.3	46/ 5.1	2000	2.61/ .294	4.25/108.0	9.84/259.9	20.0	R45GENA-TS-NS-NV-00	SC403-002-T4
142/15.9	120/13.4	64/ 7.1	61/ 6.8	1500	3.41/ .385	4.25/108.0	11.34/288.1	25.0	R46GENA-TS-NS-NV-00	SC403-013-T4

Notes: All of the systems listed have a shunt regulator installed in the controller.

Δ Peak torque ratings are for 5 seconds.

Δ Rated speeds are for 240 Vac, 3-phase operation. Derate to approximately 85% for 240 Vac, 1-phase operation. Derate to 40% for 120 Vac, 1-phase operation.

Δ Includes primary feedback inertia.

Δ Each system requires one feedback and one motor power cable.

CONNECTION DIAGRAM. . .SC400 Series Controllers

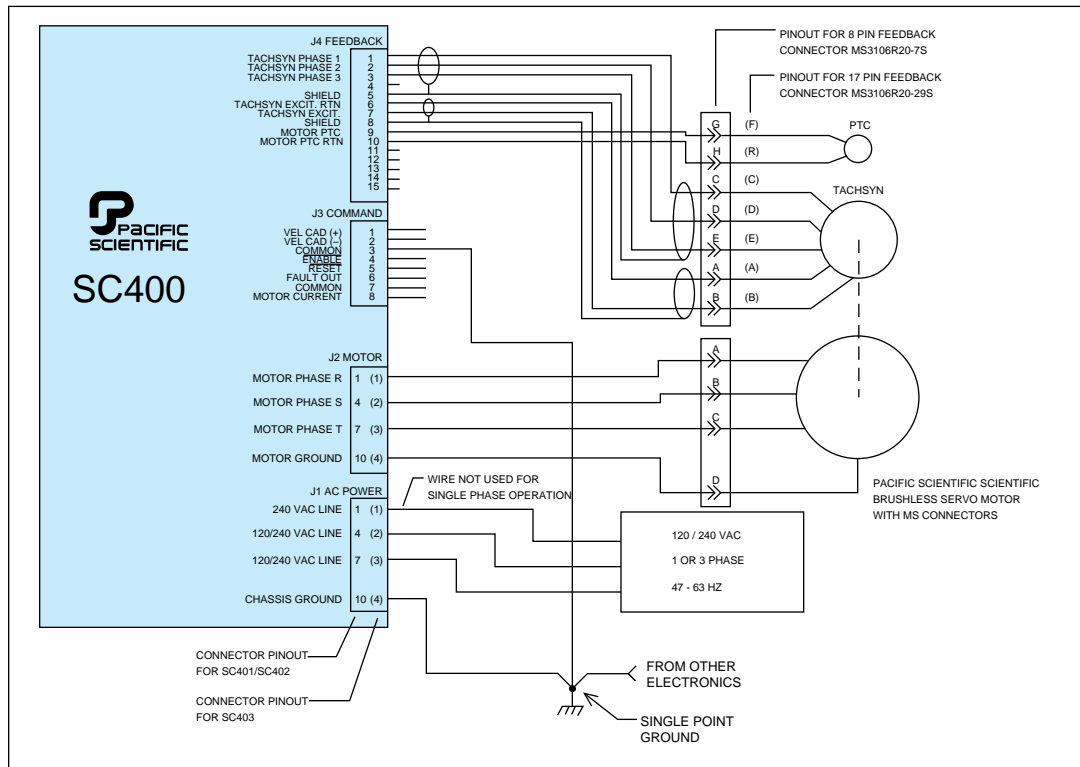

HOW TO ORDER. . .SC400 Series Controllers

To order an SC400 Series brushless servo motor controller, designate the power level desired. The middle three digits are a controller customization code, which is factory assigned. This code specifies any customization components required to match the controller to the motor. It is also used to specify any customer requested modifications. The final two digits specify the desired feedback configuration.

MODEL NUMBER CODE	
Servo controller _____	SC 4 0 X-001-T1
Series _____	
Function code _____	
0=torque/velocity controller (Hall sensors/Tachsyn®)	
Power level code _____	
2=3.8A cont./7.5A peak	
3=7.5A cont./15A peak	
Customization code _____	
Factory assigned, 001=standard unit	
Suffix code _____	
Blank=Hall sensors interface	
T1=Tachsyn® processor, 0.5 V/Krpm tach gradient	
T2=Tachsyn® processor, 1.0 V/Krpm tach gradient	
T3=Tachsyn® processor, 2.0 V/Krpm tach gradient	
T4=Tachsyn® processor, 4.0 V/Krpm tach gradient	
T5=Tachsyn® processor, 8.0 V/Krpm tach gradient	

HOW TO ORDER. . .SC400 Series Recommended Motor/Controller Systems

See the Recommended Motor/Controller Systems table on page B-61 for performance information and model numbers for servo motor/controller combinations. Order motors and controllers as separate part numbers. See brushless servo motor section for additional motor specifications and information.



DIGITAL SERVO SYSTEMS

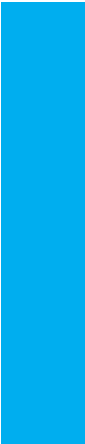

DIGITAL SERVO DRIVE

FEATURES

- Four power levels: 100 Watts, 200 Watts, 400 Watts, and 750 Watts continuous output shaft power when combined with matching motors
- Integral power supply and regeneration function
- All digital setup (no pots)
- DSD Dialog for Windows for easy setup using your PC
- Built-in display and keypad for fault diagnostics and setup without a terminal or PC
- Position mode (set\direction, step-up, setup-down or quadrature command), velocity mode (analog input or programmable internal velocity command), torque mode, and mixed mode. In mixed mode the Control-Mode-Select input is used to switch between position and velocity, position and torque, and velocity and torque modes.
- Step and direction control allows brushless servo performance with inexpensive indexer front end
- Programmable acceleration and deceleration limits in velocity mode
- Individual analog CW and CCW torque limits for position and velocity control modes
- Clutch-brake replacement
- Encoder outputs with adjustable resolution (as high as 2500 line or 10,000 quadrature counts per revolution) for external position control
- Auto-Tuning to eliminate tuning problems in many applications
- CW and CCW overtravel limit inputs
- Optically isolated discrete inputs and outputs
- Dynamic braking when power removed or optionally, when disabled
- Velocity and motor current (torque) outputs and test point

APPLICATIONS

- Packaging Machinery
- Electronic Assembly Equipment
- Material Handling
- Robotics
- X-Y Tables and Slides
- Specialty Machinery
- Multi-Axis Systems

PRODUCT DESCRIPTION

The Pacific Scientific DSD Series is a family of next generation digital servo drives. These all digital drives are capable of closing the current, velocity, and position loops. All system and application parameters are set in software to insure repeatability and to eliminate drift. The DSD Series is available in four power levels, all with integral power supplies and shunt regulators.

The base DSD unit includes several command interface features. A standard $\pm 10V$ analog interface is available to command motor torque or velocity. A count up / count down or step/direction interface is available for easy interfacing to standard stepper indexers.



FULL DIGITAL CONTROL

An all digital implementation reduces component count while increasing reliability, reducing cost, eliminate analog drift, eliminate imprecise potentiometer adjustments, reduce size, and increase flexibility.

AUTOTUNING

In many applications, the Autotuning feature will automatically set the servo system compensation parameters. You will not need oscilloscopes, meters, or other instruments - just a personal computer- to set up your system. The system allows you to select the type of performance desired.

I/O

- Differential $\pm 10V$ Analog Input 2 $\pm 5V$ Analog Outputs
- Encoder Quadrature Output
- Encoder Quadrature Input (Step/Direction, Count Up/Count Down)
- Enable Input

OPERATING FEATURES

- Smooth, digital, high bandwidth position/velocity/torque control
- Fully enclosed, panel mount package

ADJUSTMENTS

- All adjustments made in software

AGENCY APPROVAL

- Submittal to UL and subsequent recognition is pending

PROTECTION/DIAGNOSTICS

- 7 segment status display
- In-rush current limiting
- Control Power Fuse
- Output short circuit protection
- Overtemperature protection, motor and drive
- IT protection
- Under voltage protection
- Excessive regeneration protection

GENERAL...Basic Specifications...Drive

Power Source Input	
200V	Three phase 200V ~ 230V + 10% /-15% 50 / 60Hz
Analog Input Command	
Range	±10 V velocity or torque
Resolution	12 bits
Digital Input Command	
Modes	Step/Direction, Count Up/Down, Quadrature encoder
Maximum Input Frequency	
Step/Direction, Count Up/Down	500kHz
Quadrature Encoder	500 kHz Post Quadrature Frequency (125 kHz/channel)
Encoder Output Signals	
Type	Quadrature with Marker Pulse, differential TTL line driver
Resolution	2500 P/r line count
Marker Pulse Width	1 quadrature pulse nominal
Control Method	IGBT PWM (Sine Wave Control)
Feedback	Incremental encoder (2,500 P/r Standard) Differential line drive
Environmental	
Storage Temperature	-20°C to 80°C (free from dew)
Operating Temperature	0°C - 50°C (full rating) 1
Humidity	Working/Storage: 90% or less
Vibration	Not more than 4.9m / s ² (0.5G), 10-60Hz (not used continuously at the resonance point)
Altitude	1500 m (5000 ft.)

(Note¹: Linearly derate output power from full rating at 40°C to 75% of full rating at 50°C if 230 V single phase power is used)

Functions	
Control Mode	<ol style="list-style-type: none"> 1. Analogue Speed Control 2. Position Control 3. Torque Control 4. Position • Speed Control 5. Position • Torque Vontrol 6. Speed • Torque Control
Integrated Functions	
Regeneration	Regeneration resistance integrated
Dynamic Brake Function	<ol style="list-style-type: none"> 1. If disabled 2. If fault occurs 3. If power source is lost 4. During deceleration while CW or CCW drive inhibit input becomes valid
Automated Gain Tuning Function	Integrated (according to applicable motor type)
Soft Start/Stop Function	0~10s / 1000r / min (Set by parameter)
Zero Speed Clamp	Servo lock mode is obtained by inputting speed zero clamp command. (in speed control mode)
Alarm Data Trace Back Function	Traceable back to last 8 alarms (including present alarm)
Communication Function by RS-232C	Windows based setup / communication utility available for IBM compatible computer running Windows 3.1 or greater
Protection	

Description	Fault Code	Description	Fault Code
Over Voltage	.12	Over Speed	.26
Under Voltage	.13	Invalid Ratio	.27
Over Current	.14	Position Error Overflow	.29
Over Load (I*t)	.16	EEPROM Fault	.36
Encoder	.22	Simultaneous OverTravel	.38
Excessive Position Error	.24		

DIGITAL SERVO DRIVE...Connection Diagram

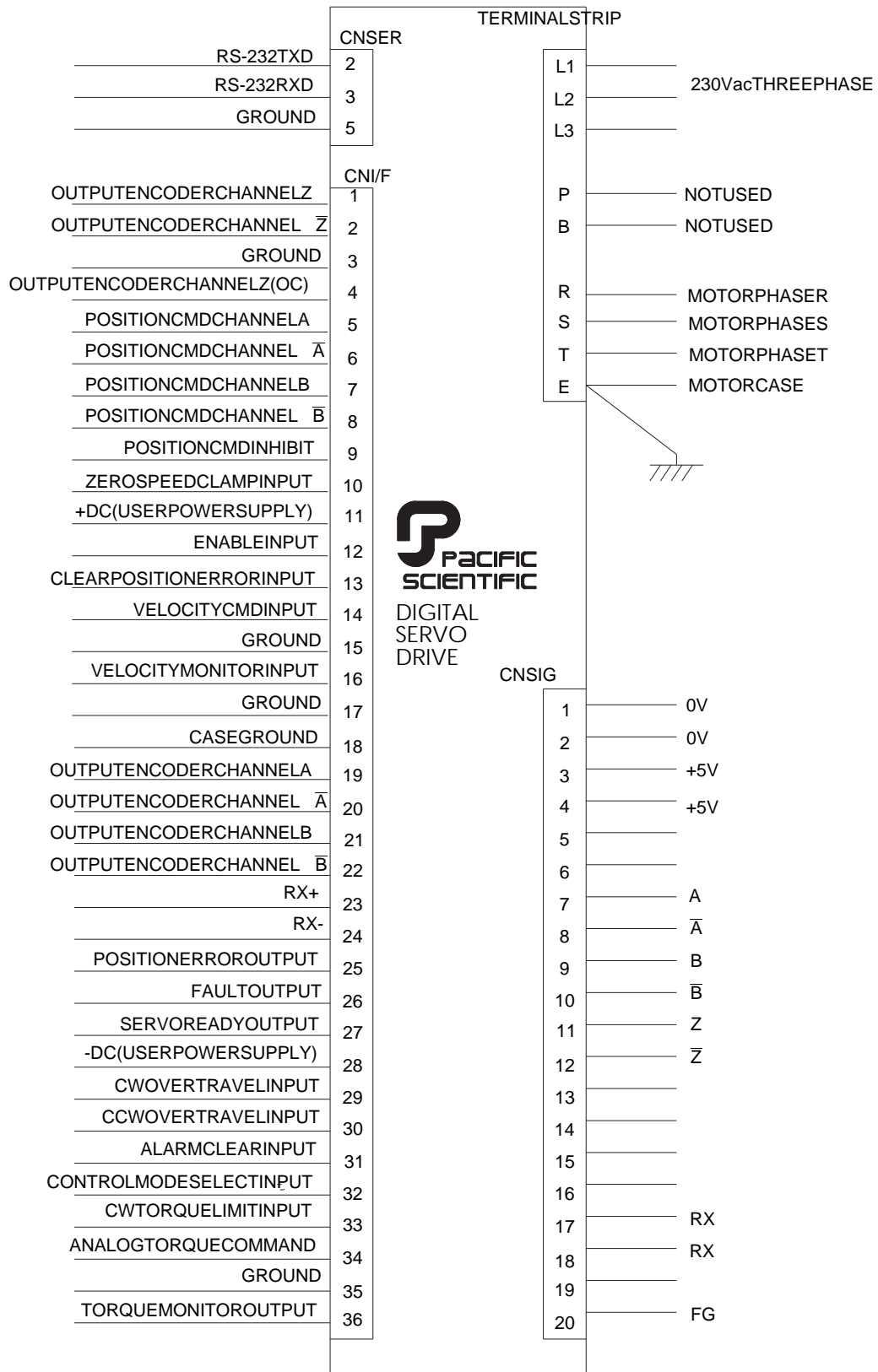

DIMENSIONS in. (metric dimensions for ref. only)

100 AND 200 WATT DRIVE

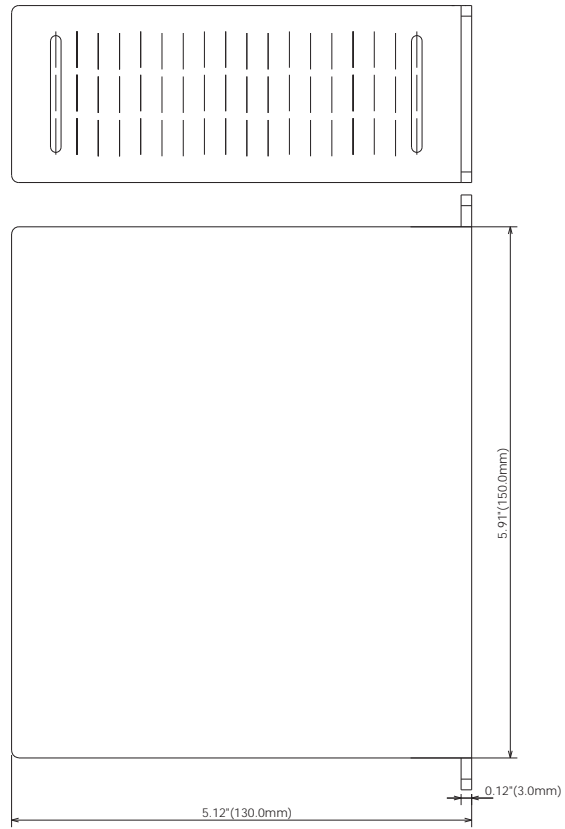
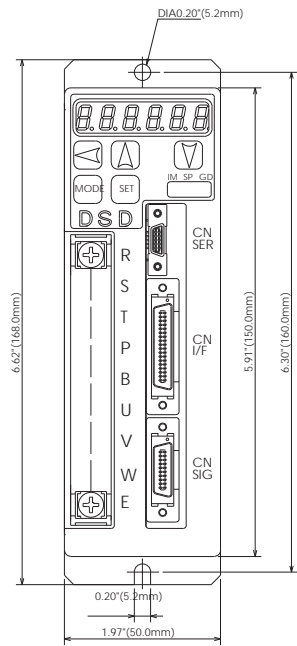

400 AND 750 WATT DRIVE

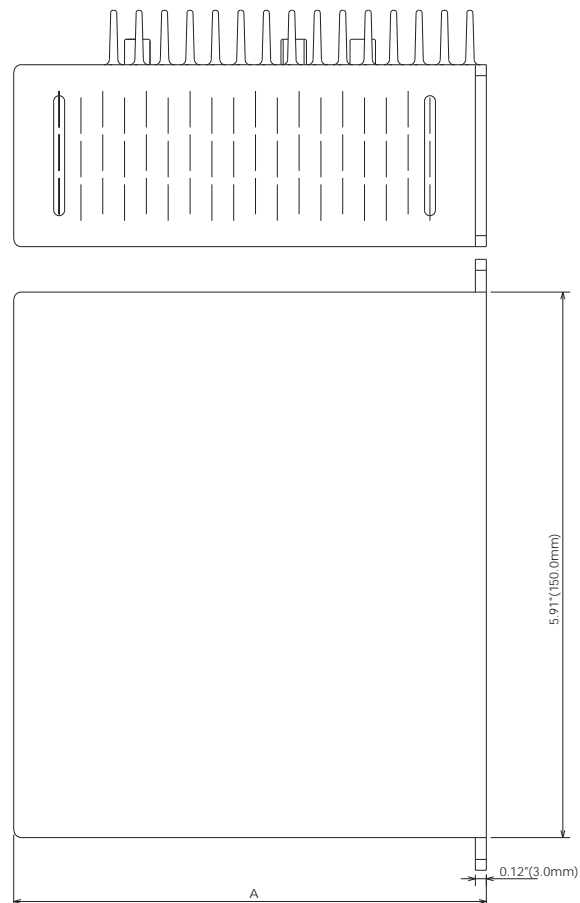
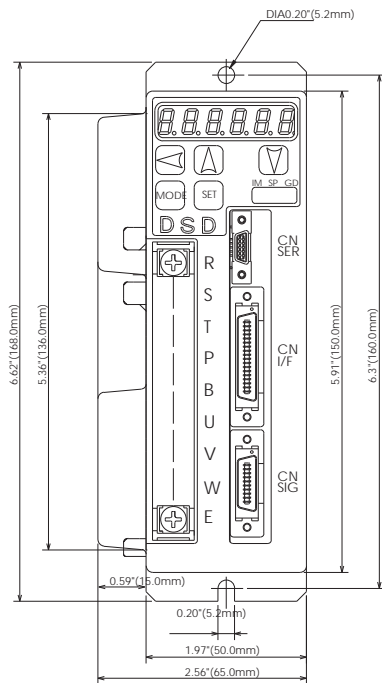

ModelNo.	A
DSD40-2A-001	5.12"(130.0mm)
DSD75-2A-001	6.70"(170.0mm)

DIGITAL SERVO MOTOR

FEATURES

- Compact Size
- Rare earth (Neodymium) Magnets provide high accel;acceleration capabilities
- Unique Stator Winding Process provides increased torque/frame size and reduced cost
- Four Power Levels
100, 200, 400 and 750 Watts continuous
3-21 lb-in at 3000 RPM
- Three different frame sizes
1.5, 2.3 and 3.2 inches
38, 60 and 80mm
- Standard Shafts include Flats or keyways
- Shaft Seals and Brakes available upon request
- Rugged Industrial Package



PRODUCT DESCRIPTION

This series of all highly Efficient and Compact Brushless Servo Motors extends Pacific Scientific's Power range down to 100 Watts continuous. This high performance series of motors features Neodymium magnets and a unique stator winding process which combine to produce excellent torque per frame size while keeping costs to as minimum.

These motors are offered with standard flats or keyways on the shafts and in three different frame sizes ranging from 1.5 - 3.2 inches.

APPLICATIONS

- Packaging Machinery
- Electronic Assembly Equipment
- Material Handling
- Robotics
- X-Y Tables and Slides
- Specialty machinery
- Multi-axis Systems
- Stepper Replacement

GENERAL...Basic Specifications...Motor

Rated Output Watts		100	200	400	750
Torque (lb-in/N*m)	Rated	2.84/0.32	5.67/0.64	11.51/1.3	21.24/2.4
	Max	8.41/0.95	16.91/1.19	33.63/3.8	63.28/7.15
Rotor Inertia (10-3 lb-in-s ²) / (x10-4 kgm ²)	W/O Brake	.056/.063	.15/.17	.33/.37	1.17/1.33
	W/Brake	.059/.067	.17/.20	.35/.40	1.25/1.41
Speed (rpm)	Rated	3000			
	Max.	5000			
Brake		DC 24V			
Encoder		Incremental 2500 PPR			
Poles		8			
Ambient Condition		Working Temperature: 0~40°C			
Weight (lbs)	W/O brake	0.53	1.17	2.12	6.84
	W/brake	0.97	1.61	3.09	8.16

SPEED TORQUE CURVES

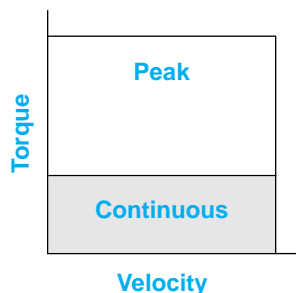

Power Watts	Peak Torque lb-in.	Continuous Torque lb-in.	Rated Speed RPM
100	8.41	2.84	3000
200	16.91	5.67	3000
400	33.63	11.51	3000
750	63.28	21.24	3000

DIMENSIONS in. (metric dimensions for ref. only)

100 WATT MOTOR

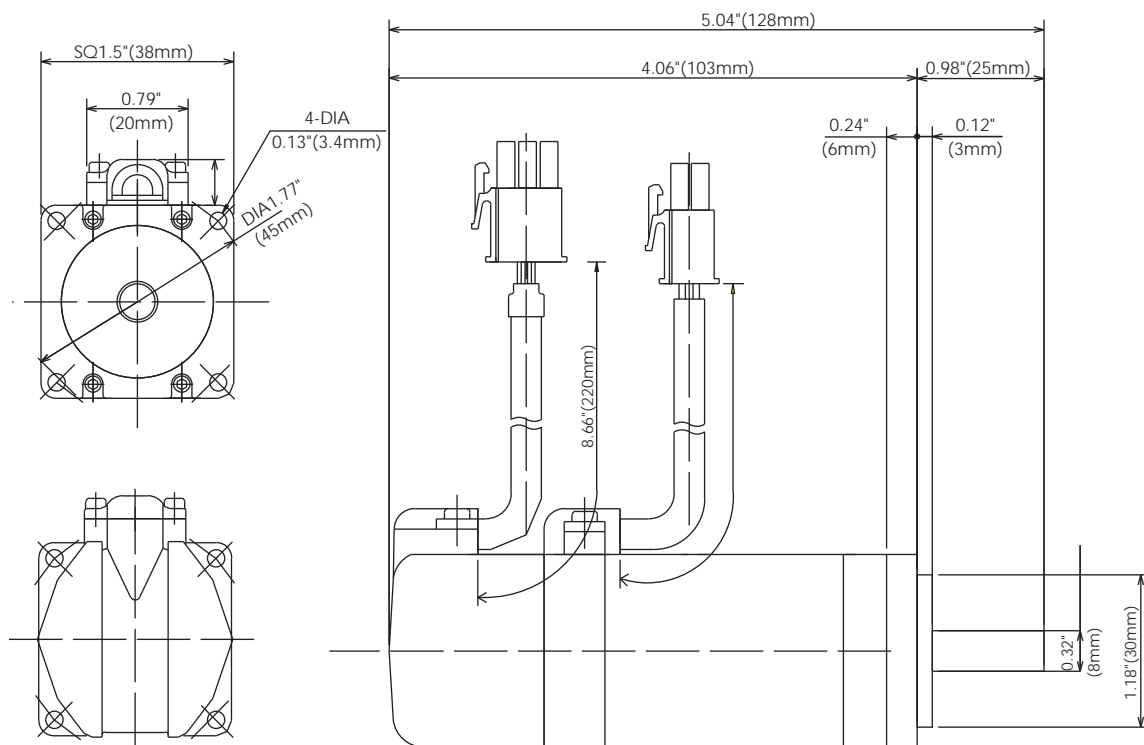

200 WATT MOTOR

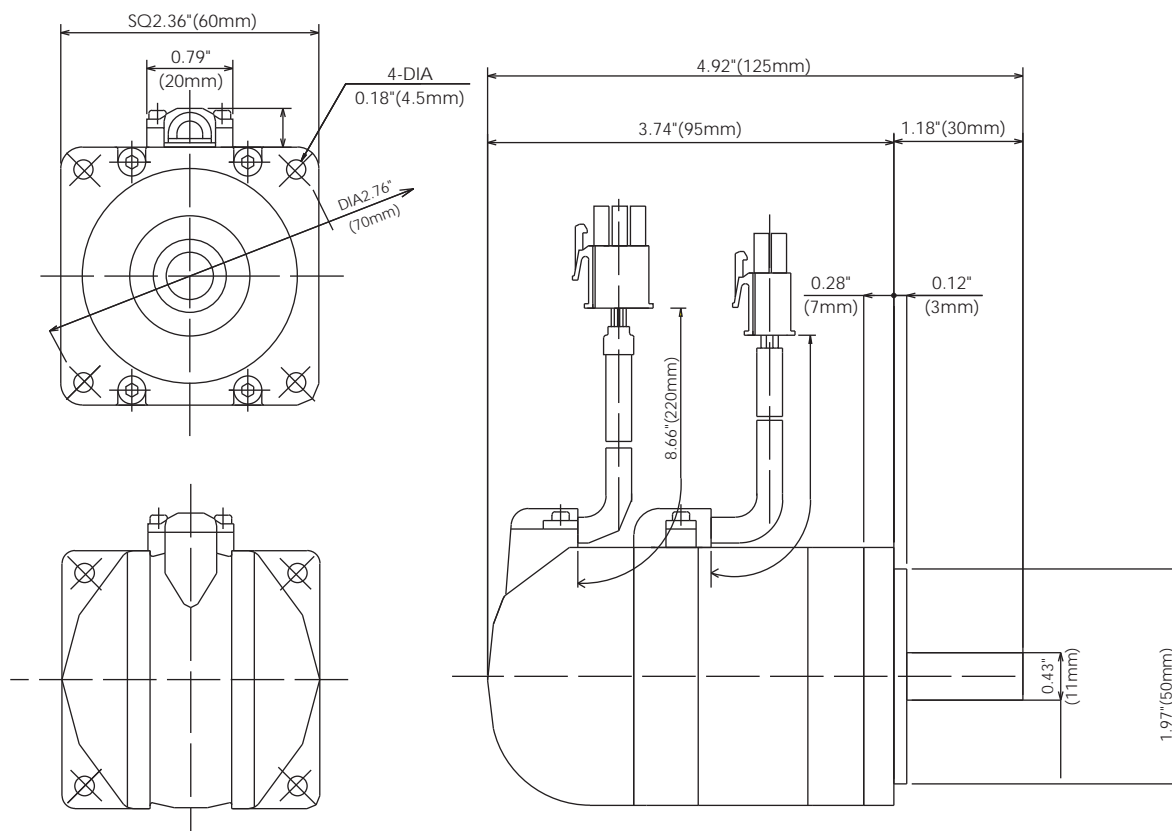

DIMENSIONS in. (metric dimensions for ref. only)

400 WATT MOTOR

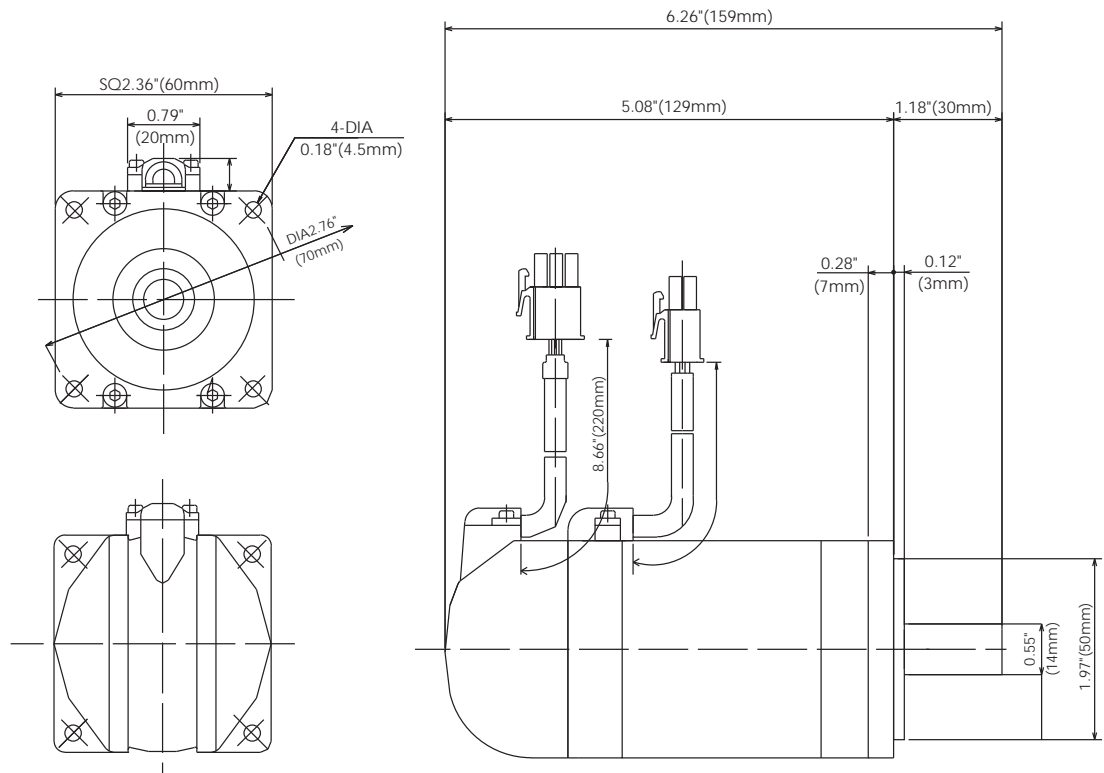

750 WATT MOTOR

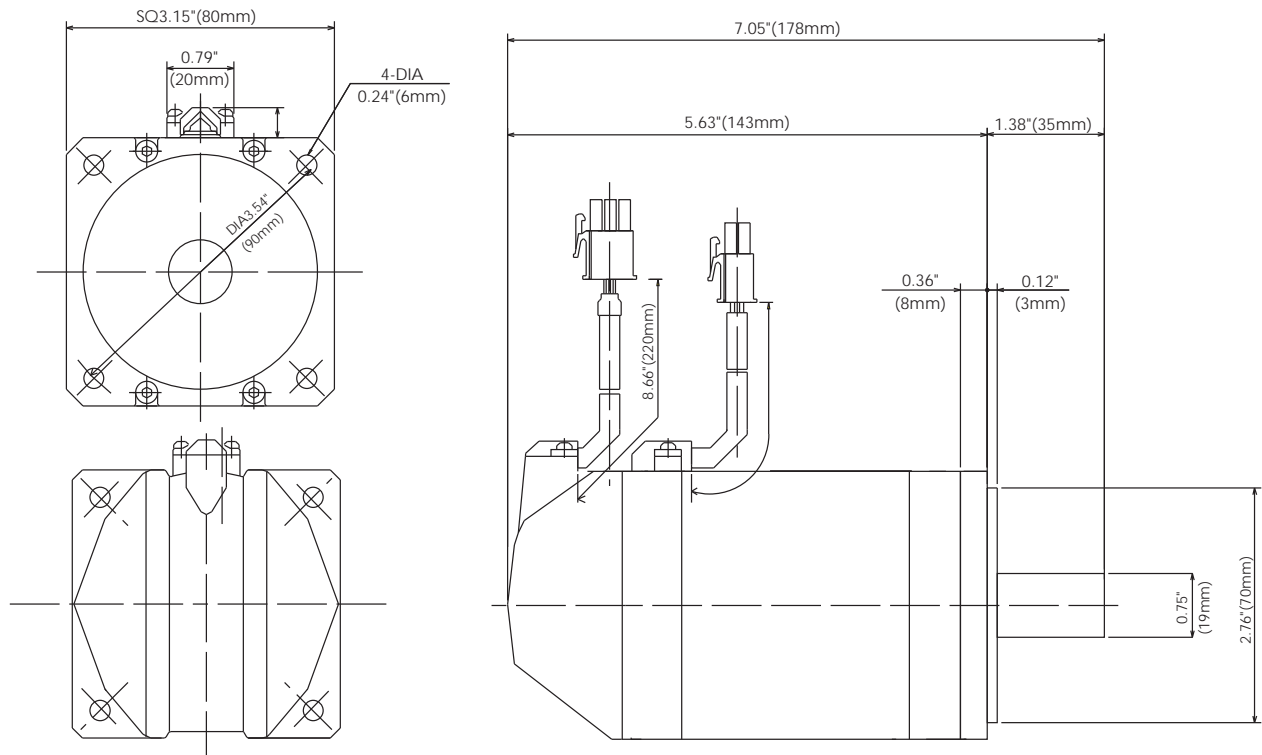

HOW TO ORDER . . . Digital Servo Drive . . . Base Drive

MODEL NUMBER CODE	DSD 10 2 A - 001
System Type (Family): _____ Brushless Digital Servo Drive (DSD)	
Power Level Designator: _____ Specifies Drive Power Ratings (ie. 100 Watt = Motor Power Input) 10 - 100 Watts 20 - 200 Watts 40 - 400 Watts 75 - 750 Watts	
AC Line Voltage Designator: _____ 2 - 230 v AC, 1Φ Operation	
Encoder Option Designator: _____ A - 2500 Pulses/Revolution, Incremental Encoder Standard	
Customization Code: _____ Factory Assigned Customization Code 001 - Standard Unit	

HOW TO ORDER . . . Digital Servo Motor . . . Base Motor

MODEL NUMBER CODE	DSM 10 2 N A - 001																																																																						
System Type (Family): _____ Brushless Digital Servo Motor (DSM)																																																																							
Power Level Designator: _____ Specifies Drive Power Ratings 10 - 100 Watts 20 - 200 Watts 40 - 400 Watts 75 - 750 Watts																																																																							
AC Line Voltage Designator: _____ 2 - 230 v AC, 1Φ Operation																																																																							
Motor Options Designator: _____																																																																							
<table border="1"> <thead> <tr> <th colspan="3">200, 400 and 750 Watt Motors</th> <th colspan="3">100 Watt Motor</th> <th colspan="4">List Price Adder</th> </tr> <tr> <th>Code</th> <th>Oil Seal</th> <th>Brake</th> <th>Code</th> <th>Oil Seal</th> <th>Brake</th> <th>100 Watt</th> <th>200 Watt</th> <th>400 Watt</th> <th>750 Watt</th> </tr> </thead> <tbody> <tr> <td>E</td> <td>no</td> <td>no</td> <td>N</td> <td>no</td> <td>no</td> <td>0.00</td> <td>0.00</td> <td>0.00</td> <td>0.00</td> </tr> <tr> <td>F</td> <td>no</td> <td>yes</td> <td>P</td> <td>no</td> <td>yes</td> <td>295.00</td> <td>330.00</td> <td>335.00</td> <td>355.00</td> </tr> <tr> <td>G</td> <td>yes</td> <td>no</td> <td>Q</td> <td>yes</td> <td>no</td> <td>40.00</td> <td>40.00</td> <td>40.00</td> <td>40.00</td> </tr> <tr> <td>H</td> <td>yes</td> <td>yes</td> <td>R</td> <td>yes</td> <td>yes</td> <td>335.00</td> <td></td> <td></td> <td></td> </tr> <tr> <td colspan="3">Note: All 200, 400 and 750 Watt Motors Supplied with Keyway</td> <td colspan="3">Note: All 100 Watt Motors Supplied with Double Flats</td> <td colspan="4"></td> </tr> </tbody> </table>	200, 400 and 750 Watt Motors			100 Watt Motor			List Price Adder				Code	Oil Seal	Brake	Code	Oil Seal	Brake	100 Watt	200 Watt	400 Watt	750 Watt	E	no	no	N	no	no	0.00	0.00	0.00	0.00	F	no	yes	P	no	yes	295.00	330.00	335.00	355.00	G	yes	no	Q	yes	no	40.00	40.00	40.00	40.00	H	yes	yes	R	yes	yes	335.00				Note: All 200, 400 and 750 Watt Motors Supplied with Keyway			Note: All 100 Watt Motors Supplied with Double Flats							
200, 400 and 750 Watt Motors			100 Watt Motor			List Price Adder																																																																	
Code	Oil Seal	Brake	Code	Oil Seal	Brake	100 Watt	200 Watt	400 Watt	750 Watt																																																														
E	no	no	N	no	no	0.00	0.00	0.00	0.00																																																														
F	no	yes	P	no	yes	295.00	330.00	335.00	355.00																																																														
G	yes	no	Q	yes	no	40.00	40.00	40.00	40.00																																																														
H	yes	yes	R	yes	yes	335.00																																																																	
Note: All 200, 400 and 750 Watt Motors Supplied with Keyway			Note: All 100 Watt Motors Supplied with Double Flats																																																																				
Encoder Option Designator: _____ A - 2500 Pulses/Revolution, Incremental Encoder Standard																																																																							
Customization Code: _____ Factory Assigned Customization Code 001 - Standard Unit																																																																							

HOW TO ORDER...DSS Series Recommended Motor/Drive

MODEL NUMBER CODE	DSD 10 - 10
System Type (Family): _____ Brushless Digital Servo System (DSS)	
Power Level Designator: _____ Specifies Drive and Motor Power Ratings 10 - 100 Watts, 230 v AC 20 - 200 Watts, 230 v AC 40 - 400 Watts, 230 v AC 75 - 750 Watts, 230 v AC	
Cable Length Designator: _____ Specifies Length of Motor Power & Feedback Cables 10 - 10 Foot Cables 20 - 20 Foot Cables 30 - 30 Foot Cables 60 - 60 Foot Cables	

ACCESSORIES:

Accessory	Description
MA-DSD	User Manual and Software Development Tool (3.5" disk)
CS-232-DSD	Serial Cable (6' only)
CP-D1-xx-DSD	Motor Power Cable (labor and connectors) Each Foot Includes spade lugs for customer AC power (xx - indicates length in whole foot increments)
CF-D1-xx-DSD	Motor Feedback Cable (labor and connectors) Each Foot. (xx - indicates length in whole foot increments)
CIO-DSD	I/O Cable, 36p HD Connector to Flying Leads (5 foot)

NOTE: All systems include each of the following....

- Brushless Servo Drive, 230 v AC (power level determined by the part number)
- Brushless Servo Motor w/ Encoder Feedback (power level determined by the part number)
- Motor Feedback Cable (length determined by the part number)
- Motor Power Cable (length determined by the part number)
- Spade Lugs for AC Input (Power cable not included)
- RS232 Serial Cable (6 foot)
- I/O Cable Adapter, 36 pin High Density Connector to Flying Leads (5 foot)
- Manual (MADSD)
- PC Setup/Communications Utility for Windows (3 Disk)

BRUSHLESS SERVO SYSTEM PERFORMANCE

System torque/speed curves on the following pages are designed to help you select the optimum brushless servo motor/controller combination.

The nominal values in these curves illustrate performance for the recommended motor/controller systems.

Want to size and select a brushless servo motor/controller on your IBM PC® or IBM compatible microcomputer? Ask PacSci or your local distributor for a copy of the Windows™- based PacSizit™ diskette.

MOTION CONTROL SYSTEM PERFORMANCE CURVES

The performance characteristics of a brushless servo system (motor/controller combination) are described by a torque/speed operating envelope. As shown below, the shaded areas of the curve indicate the continuous duty and intermittent duty zones of the system.

CONTINUOUS DUTY ZONE

The continuous duty zone is bordered by the maximum continuous torque line and the system voltage line.

The continuous torque line is set by the motor's maximum rated temperature. The system voltage line is set by the voltage rating of the controller, the line voltage supplied, and the motor winding.

The system can operate on a continuous basis anywhere within this area, assuming the motor ambient temperature is 25°C or less and the motor is mounted to the specified heat sink. Refer to the Test Conditions on the pages that follow.

INTERMITTENT DUTY ZONE

The intermittent duty zone is bordered by the peak torque line and the system voltage line.

The peak torque line is set by the controller's peak current rating, which the controller can produce for a limited time. Refer to the Rating Data on the pages that follow.

The system voltage line is set by the voltage rating of the controller, the line voltage applied, and the motor winding.

Operation in the intermittent zone must be limited to a duty cycle which will produce an RMS system torque falling within the continuous duty area. The RMS torque value is defined by the magnitude of the intermittent torque and the percentage of time spent at that torque.

ADDITIONAL REFERENCES

On the pages that follow, each individual system curve has reference points adjacent to the torque axis. In addition to rating points for peak (T_{PS}) and continuous torque (T_{CS}) ratings at stall, each curve has:

Rated speed (W_R)

Continuous torque at rated speed (T_{CR})

Peak torque at rated speed (T_{PR})

These points are provided as references for use in comparing and sizing systems. The ratings at these reference points are also provided in the Recommended Motor/Controller Systems tables with the controller specifications.

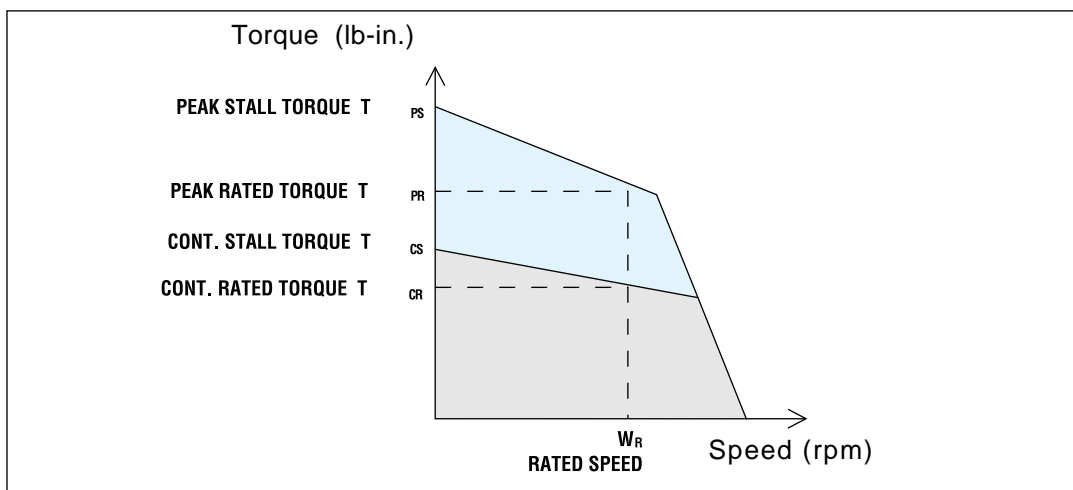

■ continuous duty ■ intermittent duty

SYSTEMS PERFORMANCE CURVES

The performance curves show the continuous and intermittent duty performance with the selected motors shown in the recommended motor/controller systems tables. The rating points on the curves are the same as those in the tables and are provided as references for use in comparing and sizing systems.

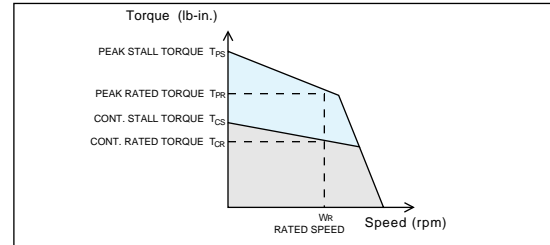

■ continuous duty ■ intermittent duty

SYSTEMS CURVES. . . SC4x2, SC7x2 or SC9x2 with R20 Series motors

Up to 7.1
lb-in. (0.8 Nm)
Cont. rated torque
@ 6000 rpm

2 in. "R" Motor

Rating Data

- Peak torque ratings are for 5 seconds.
- Rated speed is provided for operation on a 240 Vac 3-phase line. Reduce to approximately 85% for 240 Vac 1-phase line operation and to 40% for 120 Vac 1-phase line operation.

Test Conditions

- Motor operated at rated winding temperature, mounted to a 10" x 10" x 1/4" heat sink.
- 25°C ambient.

■ continuous duty ■ intermittent duty

R22H MOTOR

Reference Points	
T_{PS}	10.0
T_{PR}	6.5
T_{CS}	4.8
T_{CR}	2.5
W_R	8,000

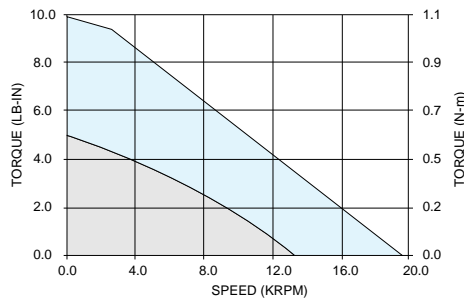

R24H MOTOR

Reference Points	
T_{PS}	17.0
T_{PR}	10.0
T_{CS}	9.2
T_{CR}	7.1
W_R	6,000

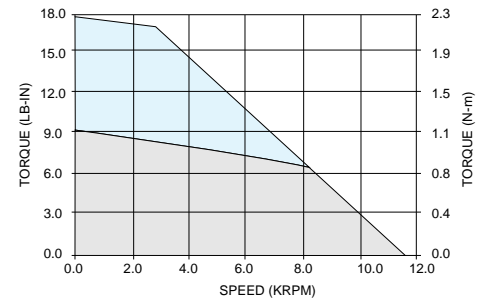

R23H MOTOR

Reference Points	
T_{PS}	14.0
T_{PR}	8.0
T_{CS}	7.6
T_{CR}	5.2
W_R	8,000

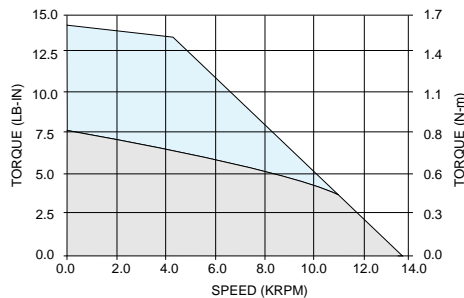

SYSTEMS CURVES . . . SC9x2/SC9x3, SC4x2/SC4x3 and SC7x2/SC7x3 with R30 motors

Up to 23
lb-in. (2.6 Nm)
Cont. rated torque
@ 3000 rpm

3.25 in. "R" Motor

Rating Data

- Peak torque ratings are for 5 seconds.
- Rated speed is provided for operation on a 240 Vac 3-phase line. Reduce to approximately 85% for 240 Vac 1-phase line operation and to 40% for 120 Vac 1-phase line operation.

Test Conditions

- Motor operated at rated winding temperature, mounted to a 10" x 10" x 1/4" heat sink.
- 25°C ambient.

■ continuous duty ■ intermittent duty

SC9x2, SC4x2 or SC7x2 and these motors

SC9x3, SC4x3 or SC7x3 and these motors

R32G MOTOR

Reference Points	
T_{PS}	27.0
T_{PR}	25.0
T_{CS}	14.0
T_{CR}	10.1
W_R	4,000

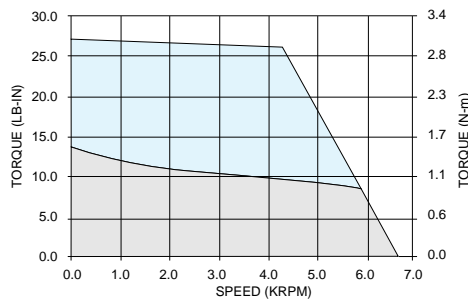

R32H MOTOR

Reference Points	
T_{PS}	27.0
T_{PR}	25.0
T_{CS}	14.0
T_{CR}	6.0
W_R	7,000

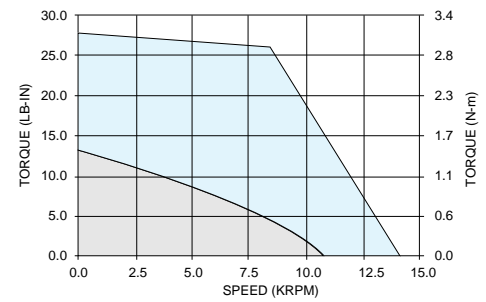

R33G MOTOR

Reference Points	
T_{PS}	36.0
T_{PR}	33.0
T_{CS}	21.0
T_{CR}	16.0
W_R	3,000

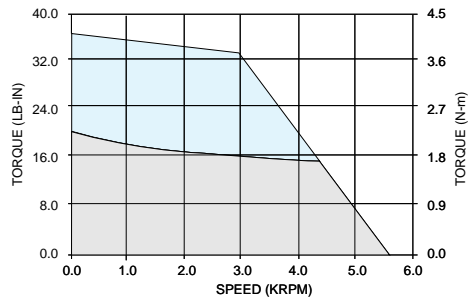

R33H MOTOR

Reference Points	
T_{PS}	39.0
T_{PR}	25.0
T_{CS}	21.0
T_{CR}	10.0
W_R	6,000

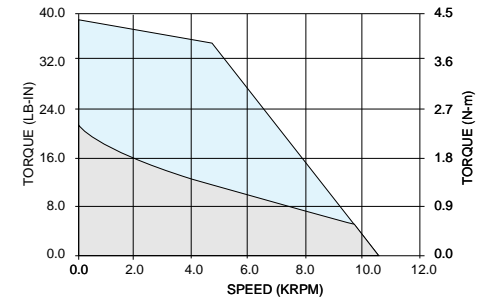

R34J MOTOR

Reference Points	
T_{PS}	45.0
T_{PR}	42.0
T_{CS}	27.0
T_{CR}	24.0
W_R	2,800

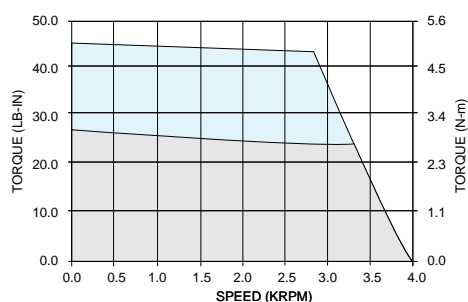

R34K MOTOR

Reference Points	
T_{PS}	48.0
T_{PR}	38.0
T_{CS}	27.0
T_{CR}	16.0
W_R	4,000

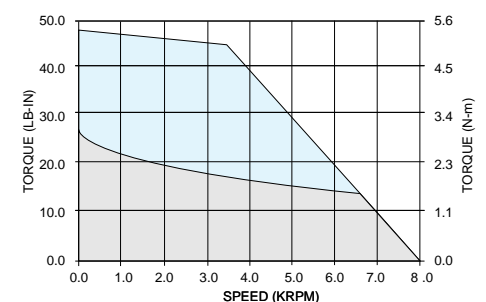

R35J MOTOR

Reference Points	
T_{PS}	54.0
T_{PR}	53.0
T_{CS}	32.0
T_{CR}	30.0
W_R	2,000

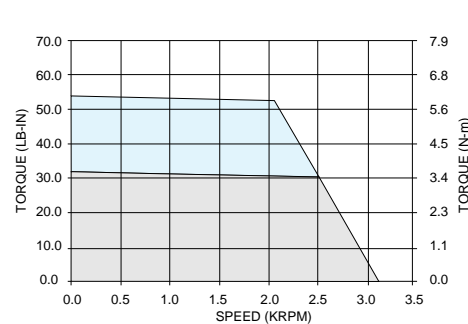

R35K MOTOR

Reference Points	
T_{PS}	59.0
T_{PR}	48.0
T_{CS}	32.0
T_{CR}	23.0
W_R	3,000

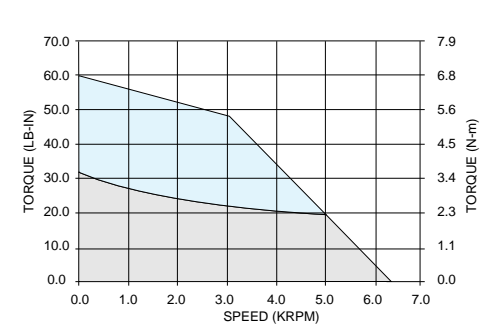

**SYSTEMS CURVES. . . SC9x2/SC9x3, SC4x2/SC4x3
SC7x2/SC7x3
with R40 motors**

Up to 61
lb-in. (6.8 Nm)
Cont. rated torque
@ 1500 rpm

4.25 in. "R" Motor

Rating Data

- Peak torque ratings are for 5 seconds.
- Rated speed is provided for operation on a 240 Vac 3-phase line. Reduce to approximately 85% for 240 Vac 1-phase line operation and to 40% for 120 Vac 1-phase line operation.

Test Conditions

- Motor operated at rated winding temperature, mounted to a 10" x 10" x 1/4" heat sink.
- 25°C ambient.

■ continuous duty

■ intermittent duty

SC9x2, SC4x2 or SC7x2

**SC9x3, SC4x3 or SC7x3
and these motors**

**R43G
MOTOR**

Reference Points	
T _{PS}	66.0
T _{PR}	50.0
T _{CS}	33.0
T _{CR}	33.0
W _R	1,800

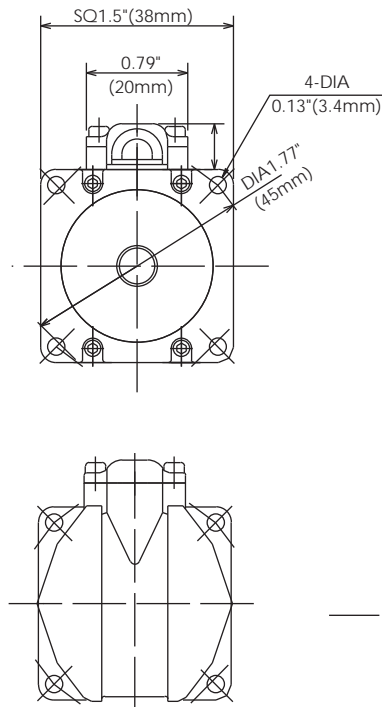

**R43H
MOTOR**

Reference Points	
T _{PS}	66.0
T _{PR}	60.0
T _{CS}	33.0
T _{CR}	31.0
W _R	3,000

**R45G
MOTOR**

Reference Points	
T _{PS}	106.0
T _{PR}	95.0
T _{CS}	48.0
T _{CR}	46.0
W _R	2,000

**R46G
MOTOR**

Reference Points	
T _{PS}	142.0
T _{PR}	120.0
T _{CS}	64.0
T _{CR}	61.0
W _R	1,500

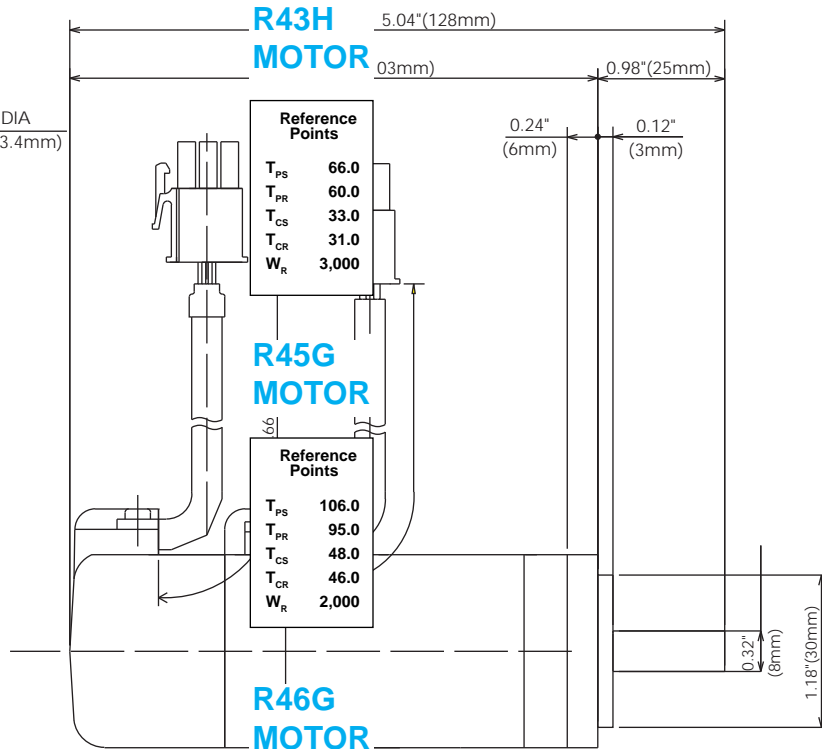

SYSTEMS CURVES . . SC9x2/SC9x3/SC9x4, with F40 Series motors (ferrite magnets)

Up to 48
lb-in. (5.4 Nm)
Cont. rated torque
@ 1500 rpm

4.25 in. "F" Motor

Rating Data

- Peak torque ratings are for 5 seconds.
- Rated speed is provided for operation on a 240 Vac 3-phase line. Reduce to approximately 85% for 240 Vac 1-phase line operation and to 40% for 120 Vac 1-phase line operation.

Test Conditions

- Motor operated at rated winding temperature, mounted to a 10" x 10" x 1/4" heat sink.
- 25°C ambient.
- 0.175 x 10e⁻³ lb-in-S² used for feedback inertia.

■ continuous duty ■ intermittent duty

SC9x2, SC9x4 and these motors

SC9x3 and these motors

F43G MOTOR

Reference Points	
T _{PS}	60.0
T _{PR}	50.0
T _{CS}	33.0
T _{CR}	32.0
W _R	1,500
W _{NL}	3,000

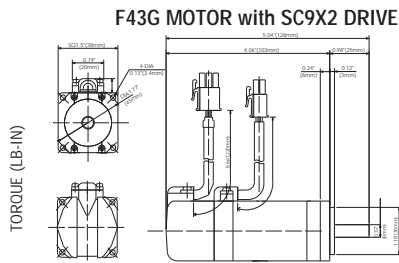

SPEED (Krpm) 320 VDC BUS

F43H MOTOR

Reference Points	
T _{PS}	60.0
T _{PR}	50.0
T _{CS}	33.0
T _{CR}	31.0
W _R	3,000
W _{NL}	5,600

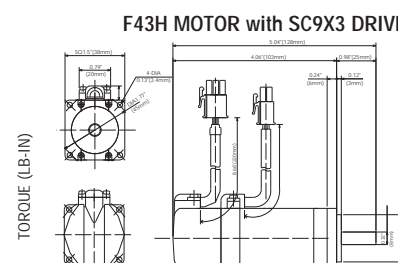

SPEED (Krpm) 320 VDC BUS

F45F MOTOR

Reference Points	
T _{PS}	80.0
T _{PR}	65.0
T _{CS}	48.0
T _{CR}	48.0
W _{R1}	1,000
W _{NL}	1,900

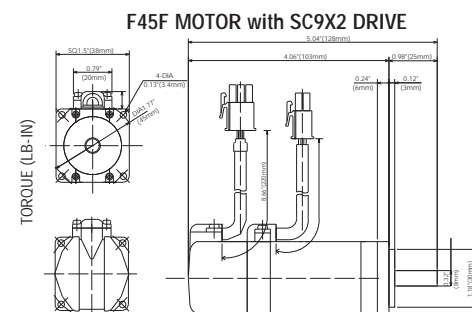

SPEED (Krpm) 320 VDC BUS

F45G MOTOR

Reference Points	
T _{PS}	80.0
T _{PR}	65.0
T _{CS}	48.0
T _{CR}	47.0
W _R	2,000
W _{NL}	3,800

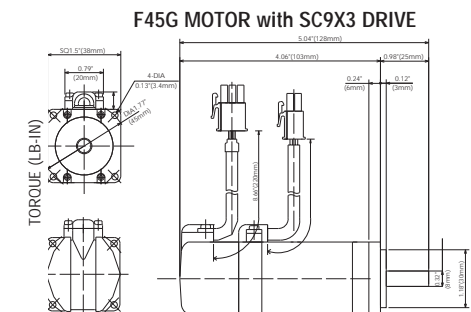

SPEED (Krpm) 320 VDC BUS

F46H MOTOR

Reference Points	
T _{PS}	115.0
T _{PR}	88.0
T _{CS}	63.0
T _{CR}	61.0
W _R	1,500
W _{NL}	2,800

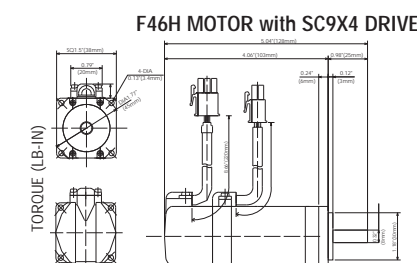

SPEED (Krpm) 320 VDC BUS

F46G MOTOR

Reference Points	
T _{PS}	115.0
T _{PR}	88.0
T _{CS}	63.0
T _{CR}	56.0
W _R	3,000
W _{NL}	5,600

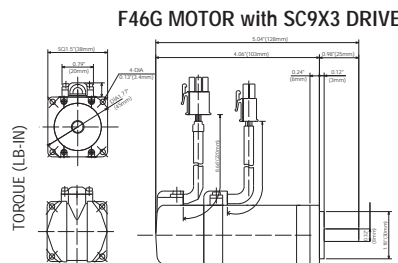

SPEED (Krpm) 320 VDC BUS